

Air-water systems for air conditioning

Design manual

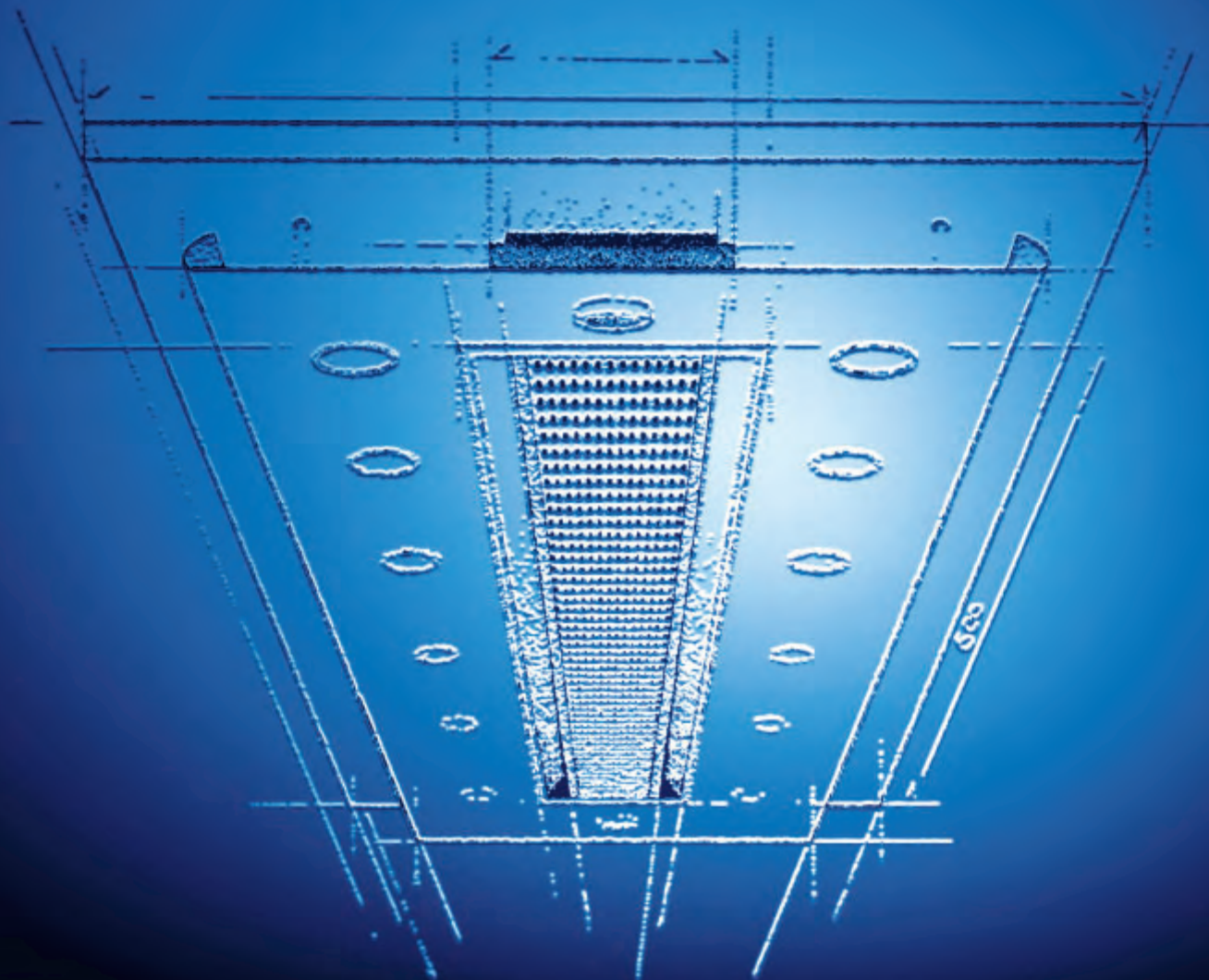

TROX[®] TECHNİK

The art of handling air



Multi-service active chilled beam MFD

Contents

Experience and innovation	3
Air – water	4
System overview	6
Passive cooling systems	10
Passive chilled beams	13
Chilled ceiling components and elements	18
Induction units	22
Active chilled beams	26
Multi-service active chilled beams	34
Under sill induction units	36
Under floor induction units	40
Façade ventilation units	44
Under sill units	53
Under sill units for projects	54
Under floor units	55
Standards and guidelines	56
Documentation	57
Project management	58
References	59

The art of handling air

TROX understands the art of competently handling air like no other company.

Working in close partnership with sophisticated customers all over the world, TROX is the leader in the development, manufacturing, and sale of components and systems for the air conditioning and ventilation of internal spaces.

The systematic research and development associated with individual products continues to expand based on project specific requirements. With its customer-specific solutions, TROX sets a trailblazing standard and continues to enter new markets and maintain sustainable business opportunities. As a result, TROX, since the introduction of the first ceiling mounted chilled beams in the 1980s, has been the leading supplier of these multifaceted products in Europe.

Products for ventilation and air conditioning technology

Components

- Air terminal devices
- Air terminal units
- Fire and smoke protection components
- Sound attenuators
- Dampers and external louvres
- Filters and filter elements

Systems

- Air-water systems
- Laboratory ventilation systems
- Communication systems for fire and smoke protection
- High density cooling solutions for data centres (AITCS)



TROX Headquarters, Neukirchen-Vluyn, Germany

TROX CUSTOMER SUPPORT

TROX places great value on customer care and provides support in the design and selection of components and systems, as well as service and maintenance, during entire project design, development, and operation phases of a ventilation and air conditioning system.

TROX in Figures

- 3,000 employees worldwide
- 380 million € turnover in 2008
- 24 subsidiaries in 22 countries
- 13 production plants in 11 countries
- 11 research and development centres worldwide
- Further more than 25 TROX sales offices and more than 50 representatives and importers across the globe



Post-Tower, Bonn, Germany

TROX has created this design manual to enable you to easily select individual types of air-water systems for a specific application. You will find a general explanation and the advantages of each system, design criteria based on European standards, economic aspects and an architectural overview.

We wish you satisfaction and success with our new design manual.

Share the experience: **The art of handling air!**

TROX[®] TECHNIK
The art of handling air

Today, air-water systems are used in many modern buildings and, especially in office and administration buildings, offer energy-efficient solutions for the internal space ventilation and air conditioning. There is a variety of installation possibilities for air-water systems, which means that, for almost every building, variants that meet the most demanding architectural requirements are available.



*Martini church, Bielefeld, Germany
All air system with jet nozzles*

In what circumstances should air-water systems be used?

For many air conditioning tasks, the internal environment is both contaminated by smells and pollutants and heated by external and internal thermal loads. Machines, devices, lighting equipment, and even the users of the space cause air contamination and thermal loads, all of which should be taken into consideration during the design. In meeting rooms, cinemas, and theatres, people are the main cause of air contamination. Good air quality can only be achieved by providing an adequate quantity of clean fresh air that takes occupancy levels into account. In these cases, the required heating and cooling capacity is provided by the supply air temperature differential. Here, a classic air system to provide air conditioning is a good choice.

Modern office and administrative buildings are equipped with a large amount of equipment and often have large areas of external glazing. The heat emission of the equipment and the solar gain can result in a considerable space heat load without the air quality being impaired by contamination.

Space cooling using an all air system would require a high air flow rate resulting in high energy costs for the air distribution system. Here, air-water systems are the ideal choice since the heating and cooling capacity of these systems can be provided independent of the required fresh air flow rate. In addition, air-water systems have the advantage that the thermal energy is transported more efficiently by water than air, this means that water has a lower energy requirement to provide the same heating or cooling capacity.

*Tholos theatre, Athens, Greece
All air system with staircase swirl diffusers and jet nozzles*



Air for the people – water for the loads

CAPRICORN House, Düsseldorf (D)
Air-water system with façade ventilation units



Occupancy by people		High Seminar room	Low Office
Air requirement			
Typical occupancy	m ² /person	3	10 to 12
Typical air flow rate	(l/s)/m ²	7	1.4 to 2.2
	(m ³ /h)/m ²	25	5 to 8
Performance data			
Typical cooling load	W/m ²	80	80
Air cooling capacity at Δt = 10 K	W/(m ³ /h)	approx. 80	18 to 26
Cooling capacity of water	W/m ²	-	54 to 62





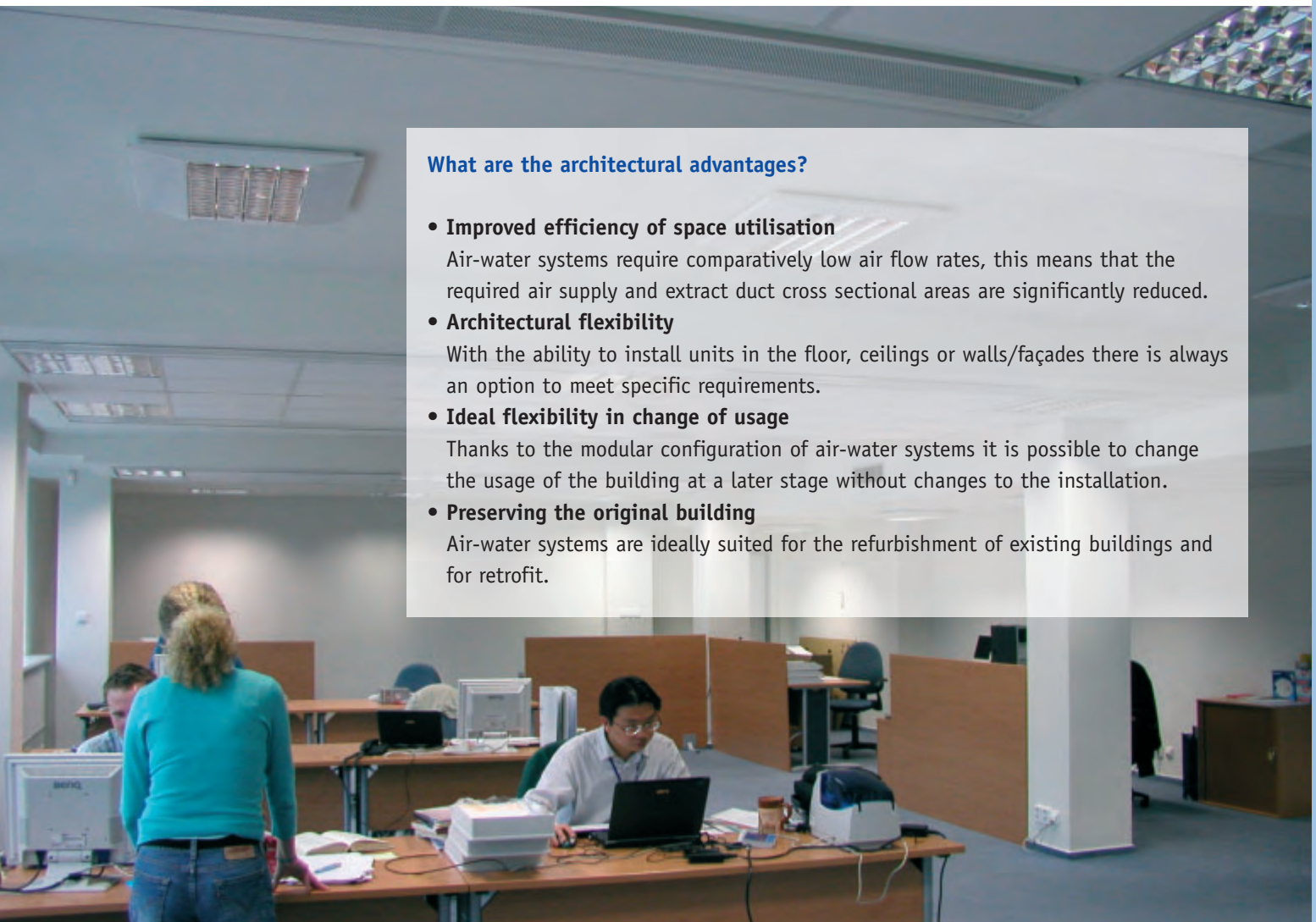



Office building, Brunn, Czech Republic
Air-water system with active chilled beams

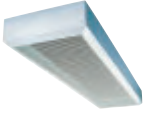

What are the architectural advantages?

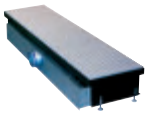
- Improved efficiency of space utilisation**
 Air-water systems require comparatively low air flow rates, this means that the required air supply and extract duct cross sectional areas are significantly reduced.
- Architectural flexibility**
 With the ability to install units in the floor, ceilings or walls/façades there is always an option to meet specific requirements.
- Ideal flexibility in change of usage**
 Thanks to the modular configuration of air-water systems it is possible to change the usage of the building at a later stage without changes to the installation.
- Preserving the original building**
 Air-water systems are ideally suited for the refurbishment of existing buildings and for retrofit.

	Passive cooling systems		Induction units			Façade ventilation units	
	Page 10		Page 22			Page 44	
	Passive chilled beams	Chilled ceiling components and elements	Active chilled beams	Under sill induction units	Under floor induction units	Under sill units	Under floor units
							
Page	13	18	26	36	40	53	55
Type of building							
Hall			•				
Hotel			•	•	•	•	•
School, university			•	•		•	
Office, administration	•	•	•	•	•	•	•
Airport, train station	•	•	•				
Installation location							
Ceiling							
Flush-mounted		•	•				
Freely suspended	•	•	•				
Floor					•		•
Interior wall				•			
External wall/façade				•		•	•
Air diffusion							
Mixed flow			•	•	•	•	•
Displacement flow				•	•	•	•
General functions							
Heating		•	•	•	•	•	•
Cooling	•	•	•	•	•	•	•
Supply air			•	•	•	•	•
Extract air			•			•	•
Additional functions							
Lighting	•	•	•				
Safety	•	•	•				
Information	•	•	•				
Sound absorption		•					
Heat recovery						•	•
Latent heat storage						•	•
Performance data							
Typical cooling capacity [W/m ²]	30 – 60	30 – 100	50 – 100	40 – 80	40 – 70	30 – 60	30 – 60
Typical fresh air flow rate [(l/s)/m ²]			1.4 – 2.2	1.4 – 2.2	1.4 – 2.2	1.4 – 2.2	1.4 – 2.2
			5 – 8	5 – 8	5 – 8	5 – 8	5 – 8
Typical sound pressure level in the space [dB(A)]	≤ 20	≤ 20	≤ 35	≤ 35	≤ 35	≤ 35	≤ 35

Depending on the building function all the systems presented here can create a comfortable indoor climate. Individual system types can provide the ideal solution for particular applications depending on the activity in the building and its proposed layout. The use of air-water systems provides performance that reacts to the specific thermal needs of an internal space.

Building types

The initial selection of a system type can be based on the proposed layout and function of the building.



• Hall

In exhibition halls the heat load mainly comes from lighting and equipment on the exhibition stands, this is usually greater than that from the people attending the exhibition.

In a factory environment there are generally few people with the main heat loads associated with the machinery. In all these applications large ceiling heights impose special requirements for the air distribution systems.



• Office, administration

In relation to the low number of people in an office the heat loads are often considerable arising from lights, computers, copiers etc. Added to this can also be solar gain. Hence, the

loads can vary significantly depending on the time of day. The system must respond to these variations.



• Hotel

The quantity of fresh air for a hotel bedroom is usually based on one or two people. The cooling loads are mainly from lighting and large areas of external glazing. The units

have to be installed in cramped locations adjacent to the hotel corridor. As these are bedrooms the units must have very low noise levels.



• Airport, train station

The characteristic of these types of buildings is that they have a variety of zones with very different functions occurring. The system selected has to be very flexible. Using an

air-water system ensures that in each zone the terminal unit delivers the required amount of cooling or heating capacity. A combination of various systems can also offer solutions for this type of application.



• School, university

In many cases, an all air system is ideal for university classrooms and lecture theatres. If the thermal loads are significant due to large areas of external glazing, lights

and computers then air-water systems can be a good option. In existing buildings if the supply air flow rate cannot be increased to meet increased loads then air-water systems can be used. In this situation the acoustic performance of such systems is critical.

Installation locations

Every system is designed and optimised for the required installation location. When the location has been established, certain systems become part of a preliminary selection.

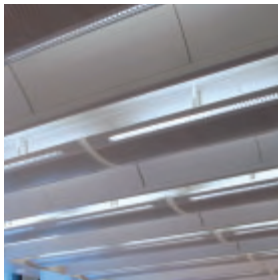

Ceiling

In many projects a false ceiling exists or is in the design. So air-water systems are ideal for integration into any kind of ceiling. Chilled beams and chilled ceiling elements in exists or is in the design, especially when freely suspended.



Floor

In modern office buildings, false floors are a part of the standard equipment. The entire open space underneath the false floor, however, is not totally required for the installation of electrical and data cabling. For this reason,

the integration of the ventilation system into false floor can be extremely interesting. Buildings with full height glass façades result in particular requirements for the building services equipment. Here also under floor units are a clever alternative.

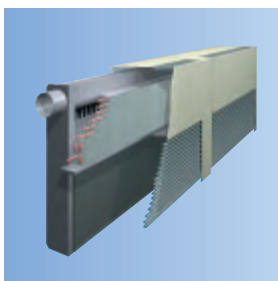

Wall surface

Under sill induction units which require no connection to the outside located at interior walls achieve a very low turbulence ventilation without draughts due to quasi displacement flow. The combination with other air-water

systems makes sense for large office spaces.

Under sill induction units for the internal zone and under floor induction units for example at the façade are a good combination.



External wall/façade

There are many possibilities at the façade for decentralised ventilation of internal spaces. Innovative solutions for new projects but also for existing buildings are available.

Integration of units in or at the façade results in improved

efficiency of space utilisation and a high degree of architectural flexibility.

Air distribution

A comfortable indoor climate in air conditioned spaces depends amongst other things on the velocity and turbulence of the air flow. This is very important in the context of the air distribution.

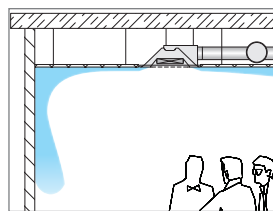

Mixed flow

The supply air is discharged into the space from the diffuser with a velocity between 2 and 5m/s. The resulting air jet mixes with the room air, ventilating the entire

space. Mixed flow systems typically provide a uniform temperature distribution and air quality within the space.

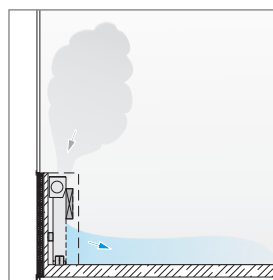

Displacement flow

The supply air is discharged into the space with a low air velocity as close as possible to the floor. This results in a pool of fresh air over the entire floor area. The convection from people and other heat sources causes the fresh air

from the pool to rise and create comfortable conditions in the occupied zone. Displacement flow systems typically provide in the occupied zone low velocities, low levels of turbulence and very good air quality.

Functions

The function of the system is essentially divided into the type of air handling and subsequent air treatment.

- Façade ventilation units directly provide filtered fresh air to the space. Depending on selection heating and/or cooling can be provided.
- In the case of induction units, the secondary induced air is suitably tempered through either heating or cooling coils.

Performance data

Essential performance criteria for system selection include the required fresh air flow rate and cooling load. Induction units are supplied by the centralised air handling system with conditioned fresh air. Façade ventilation units have the shortest possible distance in which to introduce fresh air from an opening in the wall/façade to the conditioned space. Data on the typical sound pressure level is based on a room attenuation of 6 to 8 dB.



Greater London Authority Building, London, Great Britain

Additional functions



Lighting

Passive or active chilled beams with integrated strip lighting or spotlights save space, increase the quality of the installation, and reduce the on-site interfaces.

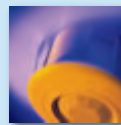

Safety

Passive and active chilled beams can be fitted with smoke detectors, sprinklers and motion sensors. Avoiding the installation of these units in multiple locations, thus improving overall building safety.



Information

Integral loudspeakers, displays, or other optical indicators such as display screens which give people in the building important information, for example, at train stations or airports.

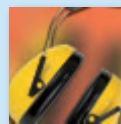

Sound absorption

Chilled ceiling components and elements with sound absorbent material can be used to optimise room acoustics and thus increase the comfort levels.

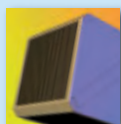

Heat recovery

An integrated heat recovery improves the systems energy efficiency.



Latent heat accumulation

Integration of phase change material (PCM) into the system allows natural cooling without a refrigerating machine using the temperature difference between day and night.



Hubert Burda Media Tower, Offenburg, Germany

Passive cooling systems

Passive cooling systems are a good solution for internal spaces with high heat loads and also important in the context of comfort. The air quality is maintained by a centralised or decentralised mechanical ventilation system. Passive chilled beams or chilled ceilings can supplement the ventilation system by dissipating heat loads using only water as a transport medium. Highest energy efficiency is achieved by optimised sizing of both systems.

In new construction projects many architectural ideas can be realised with passive cooling systems. High levels of comfort, best occupant acceptance, and low operating costs are the result. A passive chilled beam or chilled ceiling can be installed into an existing building as part of a refurbishment programme. If the heat loads increase beyond the cooling capacity of the existing air conditioning system then a passive cooling installation can make up the shortfall.



Moyland Castle, Bedburg-Hau, Germany

Functional description

The surfaces of passive cooling systems remove heat and transfer it to water, which acts as a transport medium. Heat is transferred via radiation and/or convection. Various systems have different proportions of radiation and convection.

The radiation principle

Between surfaces with varying temperatures, heat is transferred from the warm to the cold body through radiation (electromagnetic waves). Of the passive cooling systems, the (radiation) chilled ceilings remove the greatest amount of heat through radiation. The surfaces of the heat sources, such as people, office machines, and lights, radiate heat onto the surface of the chilled ceiling. For the most part, the heat is removed by the surface material of the chilled ceiling, transferred, and then dissipated by means of the chilled water.

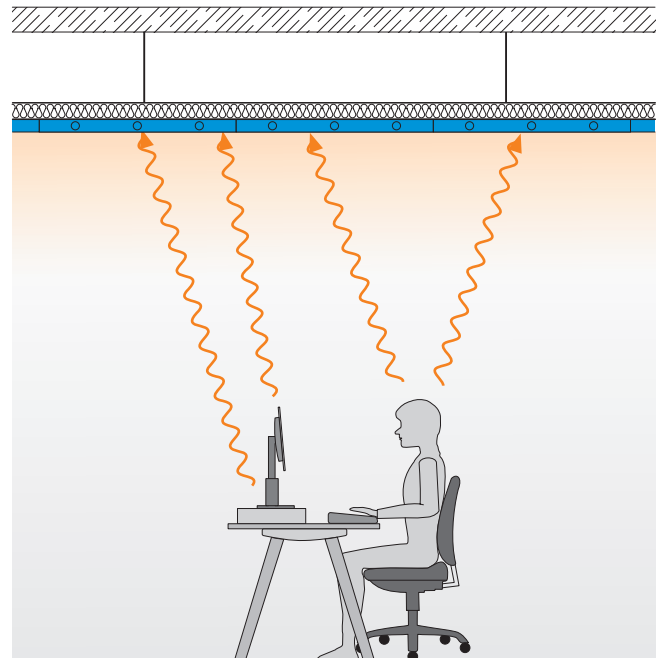

Radiation principle

The convection principle

Heat transfer through convection requires a medium (air in this case) that removes heat and transfers it to another place by air movement. In air-conditioned spaces, the air is heated by people, office machines, and other heat sources, thus becoming lighter and rising. On the surface of a heat exchanger, the air dissipates heat and thus it becomes heavier and sinks under the action of gravity.

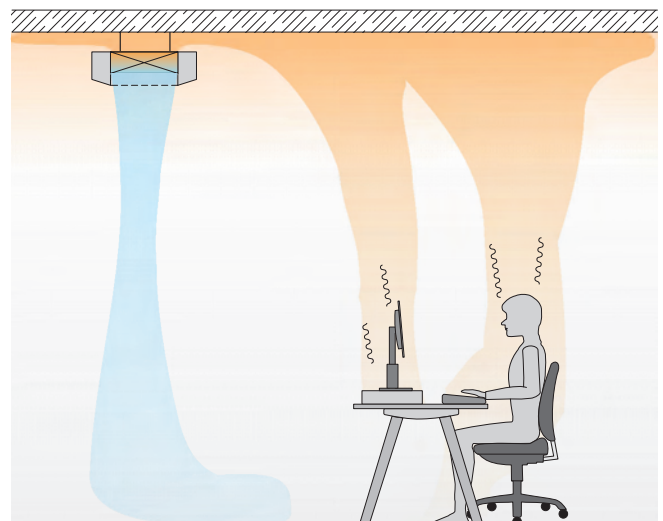

Convection principle

Advantages

- Superior levels of comfort resulting in occupant satisfaction
- Greater design freedom for architects
- Lower air velocities in the occupied zone and thus no draughts
- No-air regenerated noise
- Low operating costs
- Easy retrofit

Design information

Air quality

The passive cooling system only deals with cooling loads. A ventilation or air conditioning system is recommended to maintain the air quality. The fresh air requirement is usually relatively low (normally 2 to 3 air changes per hour). The ventilation system has the following essential functions:

- Fresh air supply for the occupants
- Extract of hazardous substances
- Control of relative humidity

Thermal output

100% of the thermal performance of passive cooling systems is produced through heat exchange with chilled water. The cooling capacity is mainly determined by the difference between the room temperature and the surface temperature of the heat exchanger. The latter depends on the chilled water flow temperature. To increase the performance requires a reduction in water flow temperature, however, this reduction should not be below the room air dew point to avoid the formation of condensation.

Dew point

In mechanically ventilated buildings, the humidity of the inside air stays within certain limits, even in summer. At a room temperature of 26°C and 50% relative humidity, the dew point temperature is approximately 15°C. Thus, the chilled water flow temperature for passive cooling systems should be controlled to not fall below 16°C. To be safe, condensation sensors should be used if the chilled water temperature can get close to room dew point.

Open windows

In the case of opening windows this can result in the humidity in the space rising and hence an increase in room dew point. The chilled water flow temperature may then be

below the dew point. To avoid this the windows should have contacts that shut off the chilled water flow when the window is opened. From an energy saving standpoint if windows are opened then the air conditioning to that particular space should be shut down.

Heating operation

Normally, passive cooling systems are optimised for cooling operation. They can, however, also be used for heating with hot water. A frequent application is heating operation in the perimeter zone when low external temperatures occur. This provides a means of reducing cold window effects and thus improving the area comfort levels.

- Passive chilled beams

Based on the convection principle, passive chilled beams heat the layer of air adjacent to the ceiling. With very high hot water temperatures a layer of hot air is generated very close to the ceiling and therefore does not extend to the occupied zone. To avoid this, hot water temperatures should not exceed 50 °C.

- Chilled ceiling

Heat exchange through radiation also starts at the ceiling. On the basis of comfort, hot water flow temperatures should not exceed 35 °C. On this basis, there would be a maximum heating capacity of 50 W/m².

Control

Attention must be paid to the control of chilled water flow temperature in passive cooling systems. The mode of operation and corresponding control depend on the design of the system. In all cases the chilled water flow temperature must not fall below the room dew point. Use of condensation sensors is recommended.

Room temperature control

The room temperature is controlled using the passive cooling system. The room temperature controller interfaces with a valve to reduce the chilled water flow rate. The components for chilled water flow and/or room temperature control and water valves can be provided as system accessories. The product sizing and selection should be undertaken in close cooperation with the design team responsible for the overall building control systems.



Swiss Post Office, Chur, Switzerland

Passive cooling systems

Passive chilled beams

Passive chilled beams dissipate large heat loads and are suited for a wide spectrum of applications and requirements. In combination with ventilation or air conditioning systems, they deal with the largest portion of the heat load. They can also be used as an effective supplement to all air or other air-water systems to provide additional cooling capacity.

Passive chilled beams do not require false ceilings and are thus an excellent choice for refurbishment and retrofit projects.

Multi-service passive chilled beams are complete building service solutions that have further functional elements in addition to air handling technology.



Hubert Burda Media Tower, Offenburg, Germany

Functional description

Passive chilled beams remove the heat from the room air and transfer it to the transport medium water. More than 90% of the heat is transferred through convection.

As the air passes over the surfaces of the heat exchanger as a result of the cooling, the density of the air increases hence accelerating the downward air flow. Additionally, as a result of the casing the downward flow is increased further (chimney effect) which in turn again increases the cooling performance.

To ensure adequate airflow through the passive chilled beam it is usually free hanging below the ceiling, however, flush installation is an option providing suitable gaps are incorporated in the ceiling to allow adequate air flow to the beam.

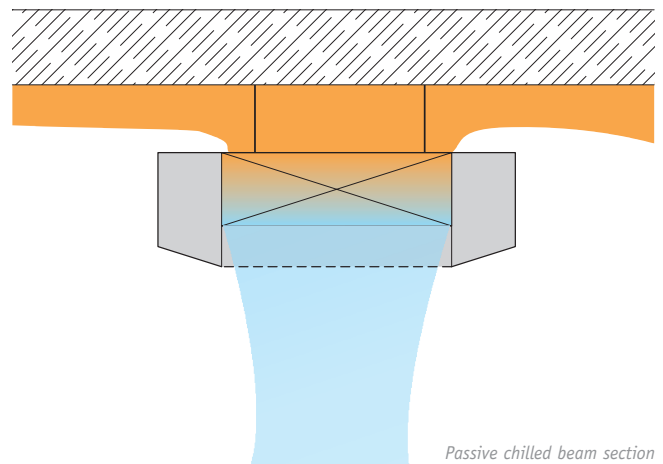

Passive chilled beam section



Düsseldorf Airport, Düsseldorf, Germany

Advantages

- Passive chilled beams are able to deal with large thermal loads within a space
- Installation into a ceiling results in a very flexible design for office areas
- Specific layout and partitioning arrangements can be accommodated
- Cooling system does not generate any noise
- The units available offer a variety of sizes providing a range of performance from low to high capacity
- Freely suspended, concealed, or flush ceiling mounting
- Multi-service functions possible
- Suitable for refurbishment projects

Multi-service capability

Like active chilled beams, passive chilled beams can fulfil additional functions. The factory installation of wiring and component piping results in a product that has a „plug and play“ facility when installed on site. This minimises the required site time for installation and commissioning.

- Integrated light fittings with various lighting system performance options
- Smoke detectors
- Sprinklers
- Loudspeakers
- Motion detectors
- Hidden integral cable trays

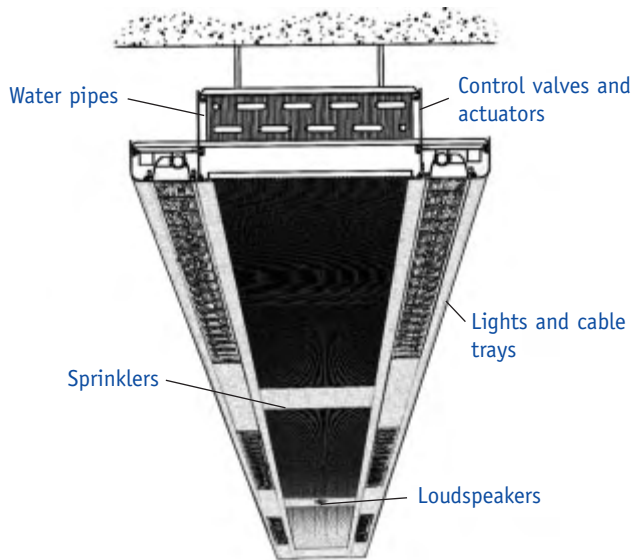

Royal Bank of Scotland Headquarters, Gogarburn, Great Britain



Design information

Design

Passive chilled beams are designed in such a way that they can be harmoniously integrated into the ceiling's visual design. The dimensions are compatible with conventional ceiling systems. When freely suspended, the passive chilled beams can provide a striking visual element of the interior design.

If the passive chilled beams are used in conjunction with a grid ceiling system, the room layout below is flexible and can be altered at a later date.

Air distribution

Depending on the product design there is a downward flow of cooled air below a passive chilled beam. In the case of large cooling capacity, discharge velocities of greater than 0.2m/s can occur below the chilled beam. This can be an issue with respect to the occupied zone depending on room height. In these situations chilled beams should be located in the aisle or corridor areas rather than directly above work stations. Installations on the building perimeter can have the advantage in summer of utilising the up currents on the inside of the glazing to enhance the performance of the beam as well as improving the local environmental comfort.

In the case of passive chilled beams that are sized for moderate levels of cooling, the specific location above the occupied zone is not critical.

Passive cooling systems

Passive chilled beams

Installation into various ceiling systems

Passive chilled beams are uniquely suited to use with all ceiling systems. The main issue is to ensure that there is a relatively unobstructed path for the airflow to the passive chilled beam inlet.

- Freely suspended
Freely suspended installation is possible for all types of ceiling system.

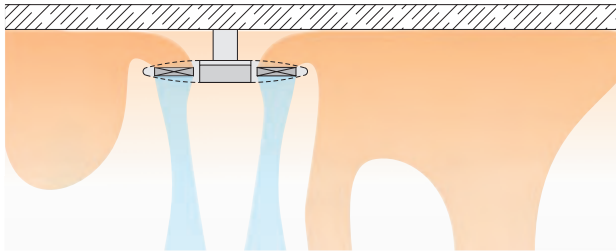

- Flush-mounted in grid ceilings
The installation of a passive chilled ceiling is independent of the adjacent false ceiling. It is essential that there are gaps between the ceiling tiles around the beams to ensure adequate airflow into the beam inlet. The total free area required should be the size (L x W) of the chilled beam inlet.

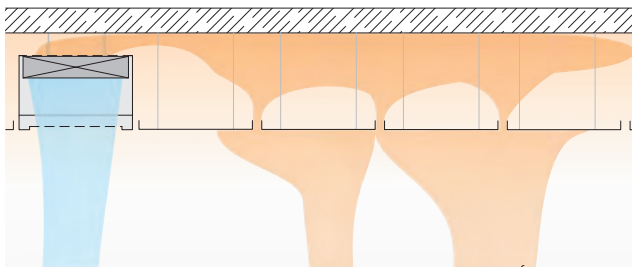

- Open grid ceilings
The passive chilled beam is freely suspended above the ceiling grid. The openings of the open grid ceiling are sufficient to ensure free air movement into the void above.

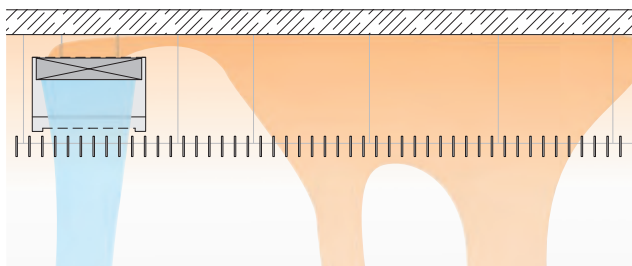

Norwich Union Headquarters, Norwich, Great Britain

- Continuous false ceilings
Flush ceiling installation into continuous false ceilings without adjacent gaps for air flow to the beam is also possible. However, in this case a return air path to the passive chilled beam inlet must be provided by a return air diffuser or perforated plate or an adequate gap between the wall and the false ceiling.

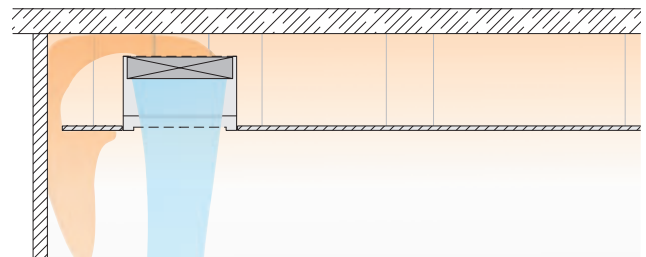
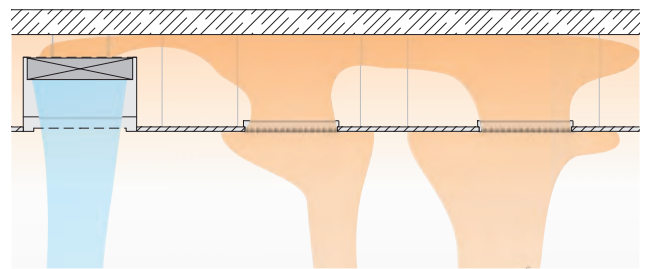

Limitations of use

- If the passive chilled beam is installed directly above a work station, the cooling capacity should not exceed 150 W/m. In case of higher capacities, locations directly underneath may become draughty.
- In comfort conditioning, adequate indoor air quality can only be achieved by using a fresh air ventilation system in conjunction with passive chilled beams.
- An opening window system for ventilation should not be used as when the external humidity is high this can result in condensation occurring on the chilled surfaces.
- In adjacent rooms without mechanical ventilation, passive chilled beams should only be used if there is no potential for high levels of moisture otherwise there is a risk of condensation.
- The maximum heating capacity can be up to approx. 150 W/m.

Unit sizing

Effective temperature difference

In addition to the construction of the beam and the material of the heat exchanger, the effective temperature difference is an important variable.

$$\Delta t_{RW} = \frac{(t_{KWV} + t_{KWR})}{2} - t_R$$

- Δt_{RW} Effective temperature difference
- t_{KWV} Chilled water flow temperature
- t_{KWR} Chilled water return temperature
- t_R Room temperature

Conversion to other temperature differences

Manufacturer's specification regarding thermal capacities is generally related to a fixed temperature difference. The expected thermal capacity for the design temperature difference can be approximately calculated using the following formula.

$$\dot{Q} \cong \dot{Q}_N \cdot \left(\frac{\Delta t}{\Delta t_N} \right)^{1,3}$$

- \dot{Q} Thermal capacity (cooling or heating)
- \dot{Q}_N Heating capacity, manufacturer's data
- Δt Effective temperature difference, for design
- Δt_N Effective temperature difference, manufacturer's data

Water flow

With the following equation, the required water flow rate can be calculated very easily.

$$\dot{V}_W = \frac{\dot{Q}}{\Delta t_W} \cdot 0.86$$

- \dot{V}_W Water flow rate in l/h
- \dot{Q} Thermal capacity (cooling or heating) in W
- Δt_W Water-side temperature difference

Correction factor for other water flow rates

The manufacturer's data usually applies to a specific water flow rate. With a higher water flow, a higher output can be achieved. Under certain circumstances, the required water flow is also smaller so that the actual output can be reduced.

Information regarding the correction factor can also be found in the unit documentation.

Sizing example

Parameters for unit sizing			
Parameters	Typical values	Example	Comments
Room temperature	22 to 26 °C	26 °C	
Ceiling area (6.0 x 4.0 m)		24 m ²	
Cooling capacity of water		840 W	
Specific cooling capacity	30 to 60 W/m ²	35 W/m ²	
Chilled water flow temperature	16 to 20 °C	16 °C	
Chilled water return temperature	18 to 23 °C	19 °C	
Results ¹⁾			
Effective temperature difference	-10 to -4 K	-8.5 K	
Possible length of passive chilled beams		5 m	
Required cooling capacity per m		168 W/m	
at -10 K		208 W/m	
Selected: 2 pieces of PKV-L/2500 x 320 x 300			Perforated plate 50% free area
Nominal cooling capacity		220 W/m	at -10 K, manufacturer's data
Chilled water flow per passive chilled beam	50 to 250 l/h	120 l/h	
Cooling capacity at -8.5 K		178 W/m	
Actual cooling capacity		180 W/m	x 1.01 correction for 110 l/h
Project cooling capacity		900 W	
Air velocity 1 m below the passive chilled beam	0.15 to 0.22 m/s	max. 0,2 m/s	
Water-side pressure drop per passive chilled beam	0.2 to 2.5 kPa/m	2.1 kPa	0.84 kPa/m

¹ Calculated with the TROX design programme

Passive chilled beams

Type PKV

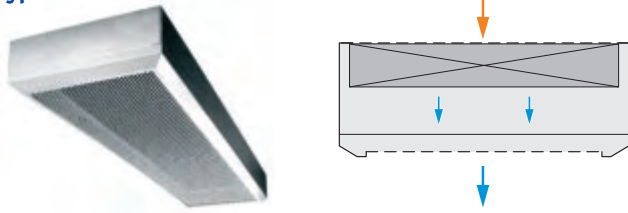

- Design variants with perimeter border and perforated face plate
- Freely suspended or flush ceiling installation

◄ L: 900 – 3000 mm · W: 180 – 600 mm
H: 110 – 300 mm

❄ Cooling capacity up to 1440 W

Multi-service chilled beams

Type PKV-B

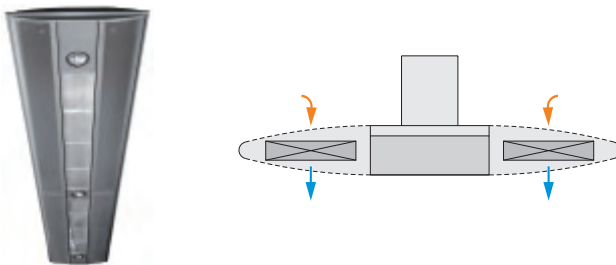

- Attractive design in a low height construction
- Also for heating operation
- Integration of linear light fittings and halogen spotlights
- Freely suspended installation
- Project bespoke multi-service integration

◄ L: 3200 mm · W: 525 mm · H: 70 mm

❄ Cooling capacity up to 255 W

🔥 Heating capacity up to 530 W

Type MSCB

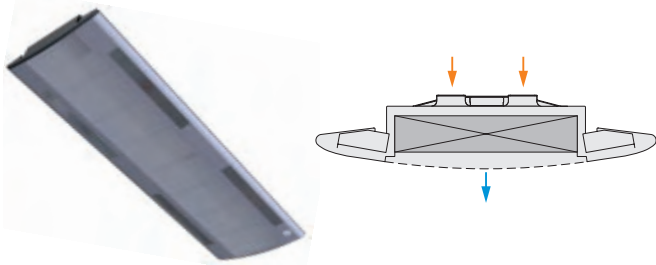

- Attractive design
- Freely suspended installation
- Cooling capacities to meet specific requirements
- Project bespoke multi-service integration

◄ L: 1500 – 3000 mm · W: 600 mm · H: 200 mm

❄ Cooling capacity up to 900 W

Passive cooling systems

Chilled ceilings · Components and elements

Chilled ceiling components and elements dissipate large heat loads, offering room occupants the greatest possible comfort and architects great design freedom in the process. Draughts and air-generated noise are virtually eliminated. There are no large vertical or horizontal temperature differences in the space thus improving comfort conditions.

In new construction projects, chilled ceiling components and elements are often chosen on the basis of architectural considerations. They require only minimal depth below the ceiling slab or false ceiling, which means that they can be used for refurbishment and retrofit even if there is initially no false ceiling present.



Swiss Post Office, Chur, Switzerland

Functional description

Chilled ceiling components and elements remove heat through their surfaces and transfer it to the transport medium water. Chilled ceilings are generally continuous suspended ceilings that operate according to the radiation principle. Chilled ceiling elements consist of cooling panels in an open design with spaces between them. The upper surface of the chilled elements are in contact with the room air, hence they remove a considerable part of the total heat load by means of convection.

Radiant chilled ceilings

Continuous radiant chilled ceilings take up the greatest portion (>50 %) of the heat load by means of radiation. The surfaces of the heat sources, such as people, office machines, and lights, radiate heat onto the surface of the chilled ceiling. For the most part, the heat is removed by the surface material of the chilled ceiling, transferred and then dissipated by means of chilled water.

In addition to the radiation, the lower surface of the ceiling imparts a lower temperature to the adjacent air. As the cooling occurs in a relatively even manner over the entire surface of the ceiling low velocity convection currents are generated.

Chilled ceiling components and tiles form a functional unit. Optimum thermal transfer is achieved by close contact of the chilled ceiling component and the ceiling tile.

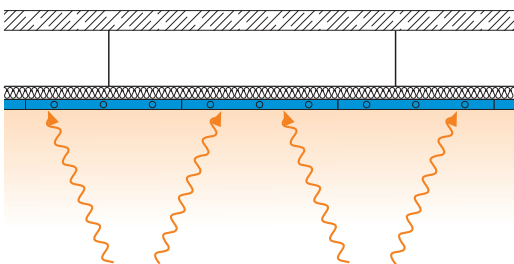

Convective chilled ceiling

Convective chilled ceilings operate on the basis of both radiation and convection principles. On the lower surfaces they absorb heat as a normal radiant chilled ceiling. The cooling panels have gaps between individual units which enables room air to have contact with the upper as well as the lower surfaces. This results in convection currents being generated, these are further amplified by the curved profiles of the elements.

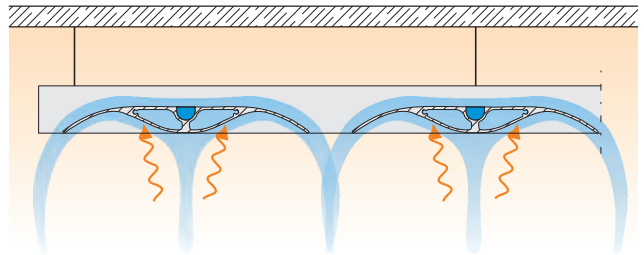

Advantages

- Superior levels of comfort resulting in occupant satisfaction
- No-air regenerated noise
- Suitable for all types of suspended ceiling
- Additional sound absorption from the ceiling
- Suitable for refurbishment projects
- Retrofit possible

Design information

Design

Almost all suspended ceiling systems are suitable to become a chilled ceiling. There is no impact on office layout, storage units and partition walls can be located as required.

Chilled ceiling components can extend over the entire ceiling area. In terms of architectural design the chilled ceiling elements can be freely suspended in a stand alone configuration including any required shape without connection to walls. Air diffusers or light fittings can also be integrated into a chilled ceiling system.

Installation into various ceiling systems

The functional chilled ceiling system is a visible suspended assembly with chilled water flow and return connections. Chilled ceiling components can be used in conjunction with most false ceiling systems. Optimum thermal transfer is dependent on the methodology used to ensure the best connection between the chilled component and the ceiling system.

- Lay in technology

Chilled ceiling components can be laid in the rear of all metal ceiling tiles. The chilled ceiling component is covered with mineral wool, and the whole is fixed into place with metal clips. The mineral wool layer is required for the cooling function. It also improves the room sound absorption.

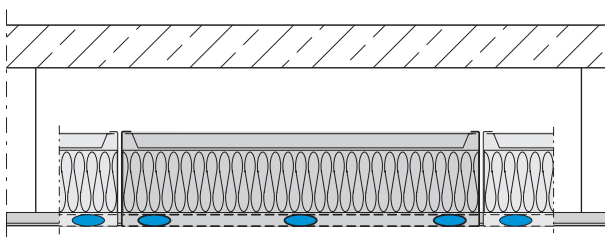

- Connection methodology

The chilled ceiling component, a layer of acoustic fleece, and the metal ceiling tile are glued together at the factory or by the customer. The adhesion technology helps achieve good thermal transfer. The acoustic fleece improves the room sound absorption.

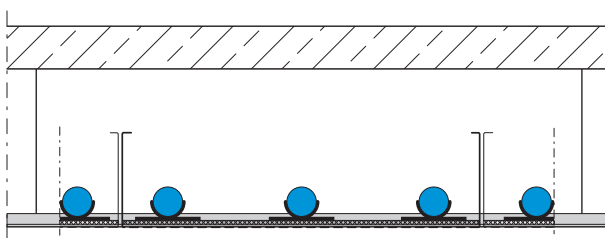

- Installation with plasterboard ceiling tiles
The chilled ceiling component is hung into the supporting profile of the ceiling. The plasterboard ceiling tile is screwed into place. A total surface contact is established between the tile and the chilled component ensuring the best thermal transfer.

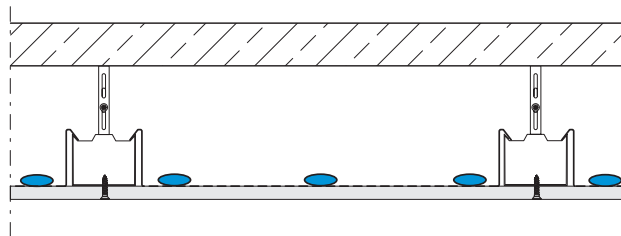

- Freely suspended chilled ceiling element or open grid ceiling.
Freely suspended installation is possible for all ceiling systems. In open grid ceilings, the units are installed above the grid.

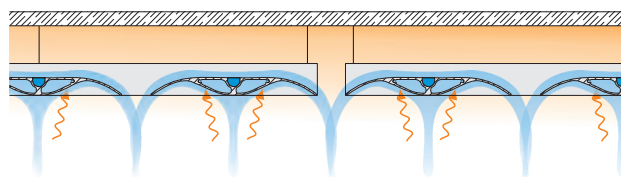

- Convective chilled ceiling elements in continuous false ceilings

A flush installation is possible in a continuous ceiling with or without gaps.

However, incorporating gaps in the ceiling will result in a greater cooling capacity and can result in an attractive appearance.

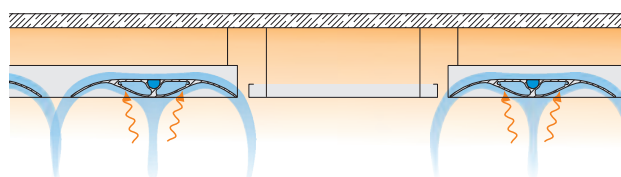

Limitations of use

- In comfort conditioning, adequate indoor air quality can only be achieved by using a fresh air ventilation system in conjunction with chilled ceilings.
- An opening window system for ventilation should not be used, as when the external humidity is high this can result in condensation occurring on the chilled surfaces.
- In adjacent rooms without mechanical ventilation, chilled ceilings should only be used if there is no potential for high levels of moisture otherwise there is a risk of condensation.

Unit sizing

Effective temperature difference

In addition to the construction and material of the chilled ceiling, the effective temperature difference is an important variable.

$$\Delta t_{RW} = \frac{(t_{KWV} + t_{KWR})}{2} - t_R$$

Δt_{RW} Effective temperature difference
 t_{KWV} Chilled water flow temperature
 t_{KWR} Chilled water return temperature
 t_R Room temperature

Conversion to other temperature differences

Manufacturer's specification regarding thermal capacity is generally related to a fixed temperature difference. The expected thermal capacity for the design temperature difference can be approximately calculated using the following formula.

$$\dot{Q} \cong \dot{Q}_N \cdot \left(\frac{\Delta t}{\Delta t_N} \right)^{1.1^*}$$

\dot{Q} Thermal capacity (cooling or heating)
 \dot{Q}_N Heating capacity, manufacturer's data
 Δt Effective temperature difference, for design
 Δt_N Effective temperature difference, manufacturer's data
 * related to type of ceiling

Water flow

With the following equation, the required water flow rate can be calculated very easily.

$$\dot{V}_W = \frac{\dot{Q}}{\Delta t_W} \cdot 0.86$$

\dot{V}_W Water flow rate in l/h
 \dot{Q} Thermal capacity (cooling or heating) in W
 Δt_W Water-side temperature difference

Correction factor for other water flow rates

The manufacturer's data usually applies to a fixed water flow rate. With a higher water flow, a higher output can be achieved. Under certain circumstances, the required water flow is also smaller so that the actual output can be reduced.

Information regarding the correction factor can also be found in the unit documentation.

Increase of capacity

An increase of capacity will occur when the chilled ceiling components are not covered with mineral fibre. The complete void is then chilled and even other ceiling areas have a chilling effect.

Values for the increase of capacity are available from the manufacturer.

Sizing example

Parameters for unit sizing			
Parameters	Typical values	Example	Comments
Room temperature	22 to 26 °C	26 °C	
Ceiling area		50 m ²	
Cooling capacity of water		2250 W	
Specific cooling capacity	30 to 100 W/m ²	45 W/m ²	
Chilled water flow temperature	16 to 20 °C	18 °C	
Chilled water return temperature	18 to 23 °C	20 °C	
Results ¹⁾			
Effective temperature difference	-10 to -4 K	-7 K	
Nominal cooling capacity	50 to 90 W/m ²		
Manufacturer's data			70 W/m ² at -8 K
Cooling capacity at -7 K		60 W/m ²	
Required area		38 m ²	2250 W / 61 (W/m ²)
Active area	60 to 80 %	76 %	38 m ² / 50 m ²
Increase in capacity		5 %	manufacturer's data
Active chilled ceiling area		35 m²	38 m² / 1.05
Chilled water flow		968 l/h	

¹ Calculated with the TROX design programme

Radiant chilled ceiling components

Type WK-D-UG



- Can fit in all ceiling tiles
 - Assembly of ceiling tiles and chilled ceiling components at the factory
 - Can be incorporated into a plaster ceiling
- ◀▶ L: max 2400 mm · W: 750 mm per element
❄ Cooling capacity up to 80 W/m²

Type WK-D-UM



Type WK-D-UL



- Can fit in all commercial ceiling tiles
 - Can be incorporated into a plaster ceiling
 - Easy assembly
- ◀▶ L: max. 2400 mm · W: 1000 mm per element
❄ Cooling capacity up to 80 W/m²

Convective chilled ceiling elements

Type WK-D-WF

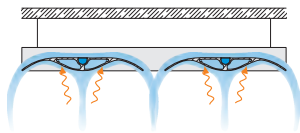

- Attractive curved shaped profiles
 - Installed as freely suspended elements (plank style)
 - Can be combined with grid ceilings
 - Also with mineral fibreboard for sound absorption
 - Can be installed above open grid ceilings
 - Project bespoke design
- ◀▶ L: max 4000 mm · W: 1400 mm
❄ Cooling capacity up to 130 W/m²

Type WK-D-EL

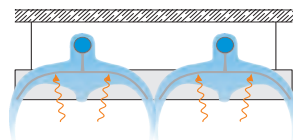

- Attractive elliptically shaped profiles
 - Optional integration of air terminal devices and lights
 - Also with mineral fibreboard for sound absorption
 - Can be installed above open grid ceilings
 - Project bespoke design
- ◀▶ L: max 6000 mm · W: 1500 mm
❄ Cooling capacity up to 110 W/m²

Chambre de Commerce, Luxembourg



Ventilation systems with centralised fresh air supply in combination with induction units giving a horizontal air discharge, can provide comfortable space air conditioning even if large cooling loads occur. The fresh air flow rate and the thermal capacity are selected independently depending on the specific requirements. These systems are thus particularly energy-efficient.

Due to the various design options, induction units are equally suited for new buildings and for the refurbishment of existing buildings.

Induction units do not require an additional fan. The induction principle causes a secondary air flow through the heat exchanger.



Hotel Straelener Hof, Straelen, Germany

The induction principle

The laws of aerodynamics for a free jet provide the basis for the induction principle.

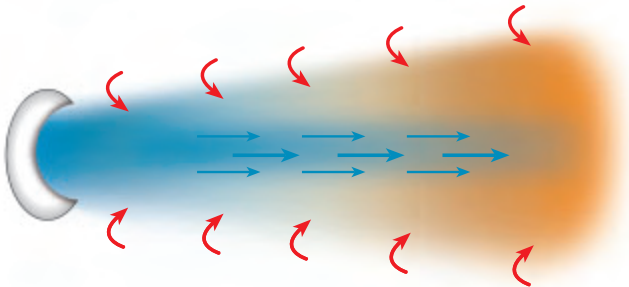

Air discharging into a large space acts as a free jet. At the point of discharge the cross-sectional area defines the flow rate, its velocity and direction of discharge. Around the boundary of a free jet the interaction with the air in the room results in acceleration of the adjacent local air. This air is induced into the jet thus increasing the total moving air flow. Since the induced air has to be accelerated

the resultant total volume of air moving slows down. This process continues until the overall air velocity falls to zero.

The discharge from every type of air terminal device results in the induction process with the room air. Horizontal discharge from the air terminal device causes the flow to continue along the ceiling surface. Hence, the induction process can only take place on the lower exposed part of the jet, this then occurs across the entire room.

In the case of induction units the induction process takes place inside the unit. The design is such that the induced (secondary) air passes through a heat exchanger. The fresh air and the secondary air, which has been heated/cooled as required, together are discharged back into the space. At the same fresh air supply flow rate the induction process results in a much higher thermal capacity than a diffuser system just supplying conditioned air from central plant.

Advantages

- Good acoustic and flow characteristics provide excellent comfort
- The fresh air flow rate can be selected to create an air quality conducive to good health
- The fresh air volume flow rate is generally constant
- The fresh air volume flow rate is only a third of that of an all air system
- A large percentage of the thermal load is dissipated with water
- Economic combination of air diffuser and water cooling system
- No additional fans to provide the secondary air
- Excellent assimilation into the interior design:
 - Harmonious integration in walls, ceilings, or floors
 - Freely suspended units as a design feature
- Reduction in space required for the air distribution system due to smaller plant rooms and ducting systems and low overall heights of the induction units
- Independent heating and cooling operation can be provided in adjacent rooms
- Additional provision of static heating systems may not be necessary
- No moving parts, resulting in operational reliability and low maintenance

Design information

Outdoor air flow rate

To achieve a good indoor air quality, centrally conditioned fresh air is supplied to the space. The required amount of fresh air primarily depends on the number of people. In case of very high thermal loads, however, a higher fresh air flow rate may be necessary so that the required capacity can be achieved.

Thermal capacity

The thermal capacity of induction units is the sum of the capacity of the fresh air and the capacity provided by the heat exchanger. The air flow rate and temperature of the fresh air are defined variables from which a certain capacity is calculated. The capacity of the heat exchanger is determined by the flow temperature of the water on the one hand and the air and water flow rate on the other. As the induction increases, the total air flow rate increases and thus so does the thermal capacity. For a unit and heat exchanger of fixed dimensions the use of different size nozzles can alter the thermal capacity. Higher levels of induction are only achieved with higher nozzle pressures and thus higher noise levels.

Dew point

In many cases, cooling operation with induction units takes place using dry (sensible) cooling. On the one hand, the humidity remains under control due to the air conditioning of the space, while, on the other hand, the flow temperature of the chilled water is controlled to an offset value above the dew point temperature of the room air. A dry operation of the units is thus guaranteed.

High cooling capacities can be achieved with wet (latent) cooling. The chilled water flow temperature in this case lies below the dew point, with the result that condensate forms in the heat exchanger. A condensate drip tray beneath the heat exchanger is essential in this case.

Even in regions that tend to have high humidity (tropics, subtropics), only units with a condensate drip tray should be considered in the design process.

Open windows

In the case of opening windows, this can result in the humidity in the space rising and hence an increase in room dew point. The chilled water flow temperature may then be below the dew point. To avoid this, the windows should have contacts that shut off the chilled water flow when the window is opened. From an energy saving standpoint, if windows are opened then the air conditioning (heating or cooling) to that particular space should be shut down.

Heat exchanger with two pipe system

The two pipe system is operated using chilled or hot water in the so-called changeover mode dependent on the outside temperature. The respective operating mode then applies for all units in the building or within a water circuit.

If the units are intended solely for cooling, for example in internal zones, or if the heating load is covered by static heating surfaces, the heat exchanger is operated only with chilled water.

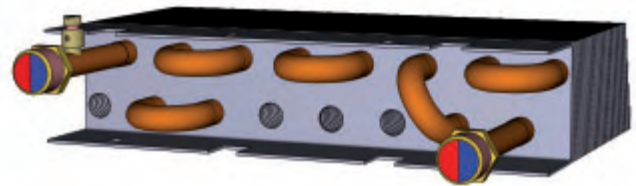

Heat exchanger with four pipe system

The four pipe system allows any room be heated or cooled at any time independent of other rooms. The heating and cooling functions each have their own water circuits. This system is well suited for buildings with diversified loads. Scheduling against outside air temperature with flexible flow temperatures guarantees energy-optimised operation. The mixing of hot and chilled water is not possible.

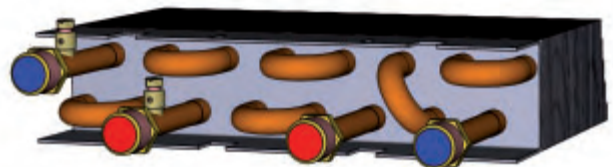

Heat exchanger without condensate drip tray

Induction units with heat exchangers without a condensate drip tray are suited for dry (sensible) cooling or solely heating operation. The heat exchanger is installed horizontally.

Heat exchanger with condensate drip tray

For wet (latent) cooling operation during which condensate forms, only units with a condensate drip tray under the heat exchanger can be considered. The heat exchanger has a vertical configuration.

Control

Conditioned fresh air flow rate

Induction units are generally operated with constant fresh air. Balancing dampers or flow rate controllers are used to distribute the required air flow rate to several units.



Balancing dampers

Commissioning is very time-consuming since the flow rate has to be measured and adjusted several times on all units.



System-powered controllers

The flow rate setpoint value is adjusted using an external scale. Further adjustment tasks are not required. Subsequent changes in the setpoint value can be easily achieved.



Volume flow limiters

Commissioning can be carried out quickly and easily. The required flow rate value is set and the volume flow limiter is inserted into the duct.



Variable air volume controllers

The fresh air flow rate is controlled using electrical or pneumatic auxiliary power. Variable volume control or day/night changeover is possible. Flow rate controllers also make sense when the air flow rate needs to be shut off or the actual flow rate needs to be provided as a voltage signal.



Room temperature

A room temperature controller controls the capacity of the heat exchanger using water valves. For four pipe systems the room temperature controller has to have two outputs one for heating one for cooling. Two pipe systems have room temperature controllers with one output, possibly with a changeover function. The control function can be implemented using electronic room temperature controllers or direct digital control (DDC) technology.

The components for adjusting or controlling the flow rate, room temperature controllers and water valves, can be installed at the factory and provided pre-wired as system accessories. The product selection and sizing should take place in close cooperation with the project participants responsible for the building management systems.

Induction units

Active Chilled Beams

Active chilled beams are suited for a wide range of applications and performance. Whether mounted flush into the ceiling or freely suspended, they are able to ventilate rooms with large thermal loads without creating draughts. Appropriate applications are perimeter and internal zones of all types of buildings that have open plan layout and cellular spaces. For high installation heights such as exhibition halls and similar areas high capacity active chilled beams can be designed for installation heights up to 25 metres.

Multi-service active chilled beams offer a complete building services solution that provides a platform for the incorporation of other systems in addition to air handling technology.



Constitution Center, Washington, DC, USA

Functional description

Active chilled beams supply fresh air to the space from a central plant room to maintain indoor air quality whilst providing cooling and/or heating using heat exchangers.

The fresh air is discharged into the beam mixing chamber via nozzles. As a result of this secondary air is induced via an inlet grille and then passes through heat exchangers into the mixing chamber. Here it is mixed with the fresh air and the total supply air is discharged horizontally into the space through integral slot diffusers.

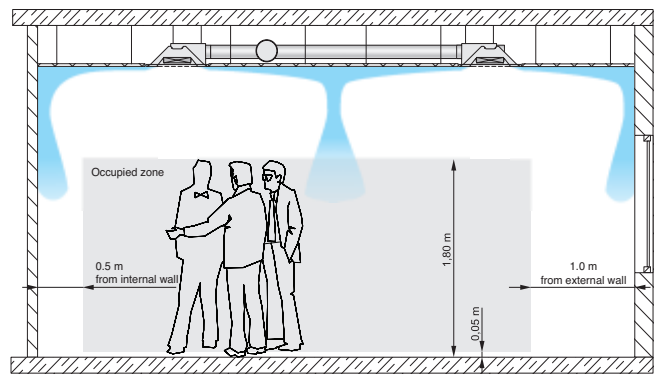

Air discharge with active chilled beams

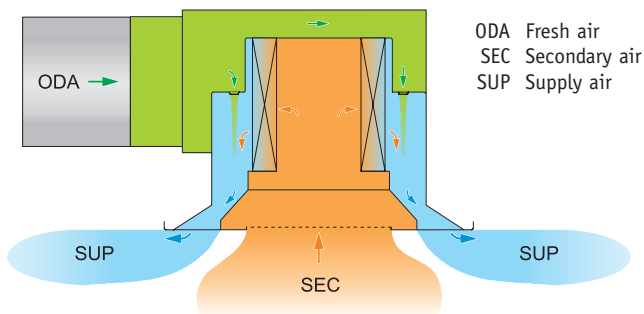

Multi-service active chilled beam MFD

The horizontal discharge into the space results in a "mixed flow" air distribution. The slot diffuser discharge velocity is selected such that the supply air penetrates into the occupied zone to maintain the air quality in the space without creating draughts. Due to induction of room air into the supply air stream in the space, the temperature differential in the air stream reduces and its velocity decreases.

Advantages

- Active chilled beams are able to ventilate spaces with large thermal loads without draughts.
- High level of flexibility of office layout due to horizontal air discharge
- Storage units and partition walls can be located as required
- Unit types with a range of sizes to provide thermal performance levels from low to high
- Larger units with high performance can be installed in the ceiling
- Often the only possibility for refurbishment of existing air distribution systems in false ceilings with low void depth
- Low height units offer advantages for both refurbishment and new build projects

Design information

General

Active chilled beams are designed in such a way that they can be harmoniously integrated into the ceiling's visual design. The dimensions are compatible with conventional ceiling systems. When freely suspended, active chilled beams can be included as a major design feature of the interior design.

With various configurations of the induction grille there is again an opportunity to complement the interior design. If the active chilled beams are located on a grid basis this offers flexibility in room sizing to reflect any future changes in requirements.

Horizontal air discharge

The supply air is discharged from the active chilled beam at a relatively high velocity (2 to 4 m/s) which enables effective room ventilation. In the occupied zone the air velocity should not exceed 0.2m/s. This is generally the case when the air stream travels a significant distance before entering the occupied zone. For a given room height the minimum discharge distance to the nearest wall must be considered. If active chilled beams are installed adjacent to each other in a space, again the minimum distance between two beams must be considered

Ceiling arrangement

Whether active chilled beams can be arranged parallel or perpendicular to the façade primarily depends on the layout of the ceiling panels. The layout has considerable influence on the horizontal air discharge in the space and should thus be taken into account at the design stage as it depends on the room depth, module width, intended use, and flexibility required.

- Parallel to the façade
The ventilation of the entire room volume is the optimum case. The air discharges towards the façade and towards an internal wall or zone across the entire width of

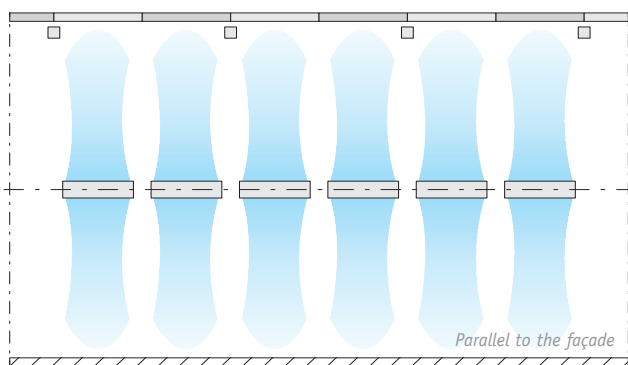

the module. The discharge towards the façade brings thermal advantages: on the one hand the window surface is kept at a moderate temperature, on the other the air velocity and its temperature difference reduce outside the occupied zone. Any infiltration through the façade is mainly dealt with by the supply air stream thus reducing the risk of draught and condensate forming at the heat exchanger.

An active chilled beam for each module allows a room division with high degree of flexibility during initial use and layout changes in the future.

- Perpendicular to the façade
The perpendicular arrangement possibly leads to a reduced number of active chilled beams and thus lower costs. The effects on the horizontal air discharge, the air distribution across the modules, and the resulting flexibility, however, need to be considered.

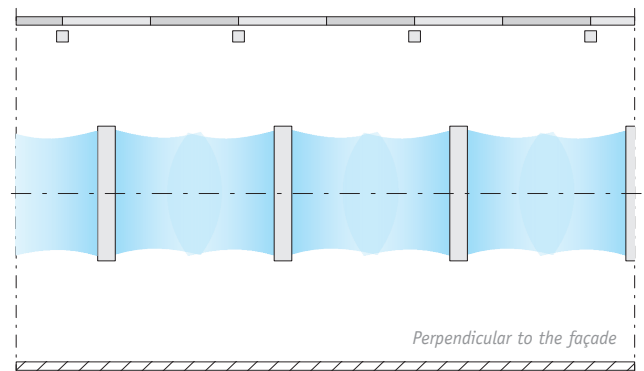

If the length of the active chilled beams is related to the room depth, a better horizontal air discharge can be achieved. On the basis of the air flow rates and thermal performance one active chilled beam suffices for three to five modules. However, flexibility is reduced. An active chilled beam for each module results in an insufficient ventilation of the space. The distance between two beams is less than the minimum recommended, this results in too high an air velocity entering the occupied zone. In practice, one beam should supply at least two modules. The air movement in the space runs parallel to the façade. Infiltration may come into the space perpendicular to the face of the glazing and cause draughts in this area and condensate forming at the heat exchanger. If flexibility is not a priority, that is, the room sizes and usage are fixed, the perpendicular arrangement can be appropriate.

Adjustable horizontal air discharge

If a large cooling capacity is required in a very small space with active chilled beams, the use of an adjustable horizontal air discharge can still result in acceptable air velocities in the occupied zone. The spread of the air discharge can be increased dependent on room geometry. In case of change of use the air discharge can be optimised by subsequent adjustment.

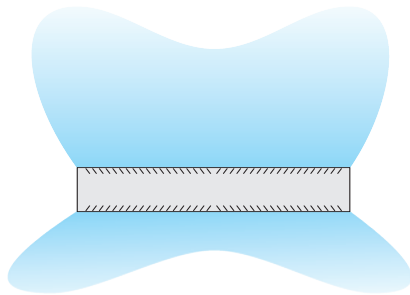

Several square active chilled beams can be adjusted in such a way that the air streams do not collide directly with each other but the air streams are adjacent to each other at their boundaries.

In this way eddies occur that result in a rapid reduction of air velocity and temperature difference in a short distance.

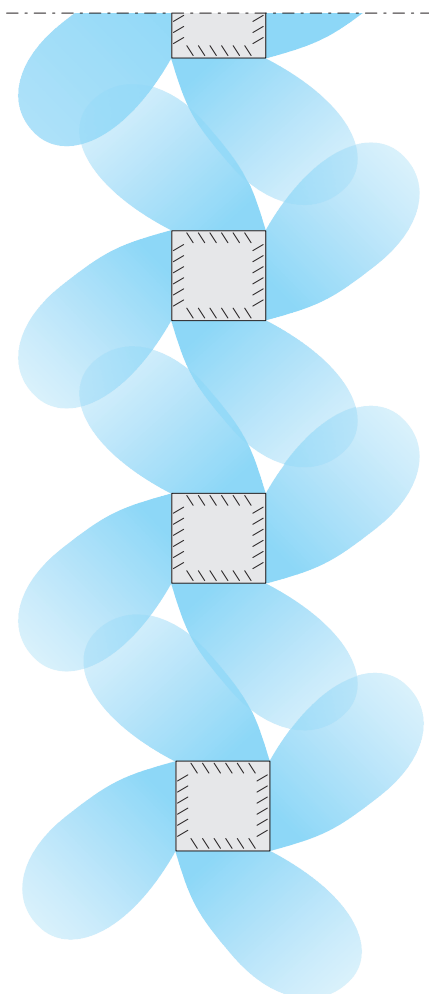

Volksbank Salzburg, Salzburg, Austria

Freely suspended or flush ceiling mounting

Whether active chilled beams are mounted flush in the ceiling or freely suspended is not just a question of architectural design. Flush ceiling installation is an aerodynamic necessity for certain types of discharge. The horizontal air flow requires the ceiling to maintain the horizontal direction so that it does not just “fall” into the occupied zone with a correspondingly low temperature in the direct vicinity of the active chilled beam. This can lead to draught problems in the occupied zone. In any case selection of the flow rate for active chilled beams should consider the proposed installation situation to ensure comfort conditions are achieved in the occupied zone.

Induction units

Active Chilled Beams

Installation into various ceiling systems

Active chilled beams are suitable for all types of ceiling systems and the dimensions of the units correspond to normal standards. Due to design details, installation can easily be with a flush fitting.

- Grid ceilings

Active chilled beams and ceiling tiles are supported independently. The edge of the chilled beam lies flush to the ceiling tile.

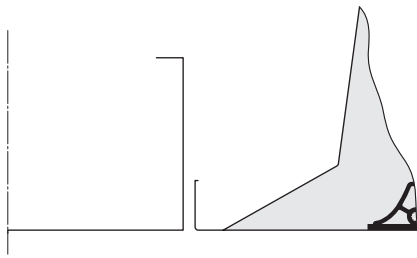

- Plasterboard ceilings

The ceiling tile overlaps the straight edge of the active chilled beam.

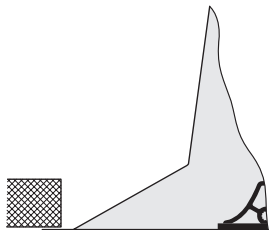

- T-bar ceilings

The active chilled beam lies on the T-bar.

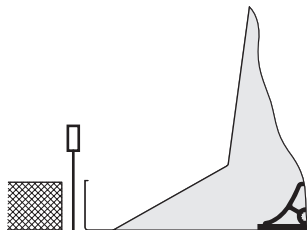

Limitations of use

- The minimum ceiling or installation height should not be below 2.60 m.
- In case of ceiling or installation heights up to 3.80 m, the supply air will reach the occupied zone without taking special action. Spaces with very high mounting heights are ideally ventilated using Type IDH active chilled beams. Intermediate mounting heights require project-specific solutions.

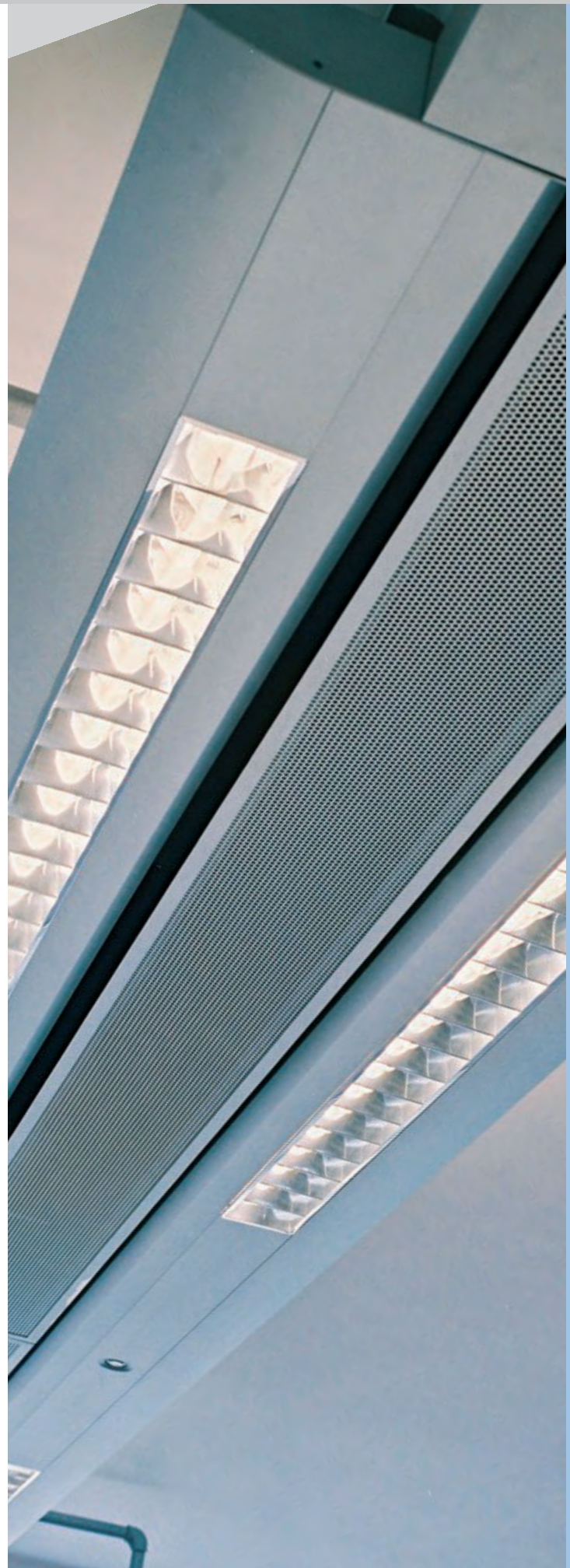

Unit sizing

Effective temperature difference

In addition to the construction and material of the heat exchanger, the effective temperature difference is an important variable.

$$\Delta t_{RW} = \frac{(t_{KWV} + t_{KWR})}{2} - t_R$$

- Δt_{RW} Effective temperature difference
- t_{KWV} Chilled water flow temperature
- t_{KWR} Chilled water return temperature
- t_R Room temperature

Conversion to other temperature differences

Manufacturer's data regarding thermal capacity is generally related to a specific temperature difference. The expected thermal capacity for the design temperature difference can be approximately calculated using the following formula.

$$\dot{Q} \cong \dot{Q}_N \cdot \frac{\Delta t}{\Delta t_N}$$

- \dot{Q} Thermal capacity (cooling or heating)
- \dot{Q}_N Heating capacity, manufacturer's data
- Δt Effective temperature difference, for design
- Δt_N Effective temperature difference, manufacturer's data

Water flow

Based on the equation below the required water flow rate can easily be calculated.

$$\dot{V}_W = \frac{\dot{Q}}{\Delta t_W} \cdot 0,86$$

- \dot{V}_W Water flow rate in l/h
- \dot{Q} Thermal capacity (cooling or heating) in W
- Δt_W Water-side temperature difference

Correction factor for other water volume flow rates

The manufacturer's data usually applies to a fixed water flow rate. With a higher water flow, a higher thermal capacity can be achieved. Under certain circumstances, the required water flow is also reduced so that the actual capacity can be reduced.

Information regarding the correction factor can also be found in the unit documentation.

Sizing example

Parameters for unit sizing			
Parameters	Typical values	Example	Comments
Room temperature	22 to 26 °C	26 °C	
Ceiling area (module 1.5 x 6.0 m)		9 m ²	
Cooling capacity		620 W	
Specific cooling capacity	50 up to 100 W/m ²	70 W/m ²	
Fresh air flow rate	5 to 8 (m ³ /h)/m ²	60 m ³ /h	
Fresh air temperature		16 °C	
Chilled water flow temperature	16 to 20 °C	16 °C	
Chilled water return temperature	18 to 23 °C	18 °C	
Results ¹⁾			
Cooling capacity of air		200 W	
Effective temperature difference	-10 to -4 K	-9 K	
Required cooling capacity of water		420 W	620 - 200 W
Cooling capacity at -10 K		467 W	
Chilled water flow	50 to 250 l/h	185 l/h	
Cooling capacity at -10 K and 110 l/h		409 W	/ 1.14 correction to 110 l/h
Selected: DID300B-M/1350 x 1200			Nozzle type: M
Nominal cooling capacity		410 W/m	at -10 K, manufacturer's data
Project cooling capacity		621 W	421 + 200
Air velocity at the wall	0.2 to 0.4 m/s	0.36 m/s	Height: 1.80 m
Water-side pressure drop	2.0 to 20 kPa	4.3 kPa	
Sound pressure level	25 to 40 dB(A)	31 dB (A)	with 6 dB room attenuation

1 Calculated with the TROX design programme

Induction units

Active Chilled Beams

	DID312	DID300B	DID604	DID632	AKV	DID-R	DID-E	IDH	
									
Installation details									
Freely suspended					•			•	
Grid ceilings	300 mm	300 mm	600 mm	600 mm	300 mm				
T-bar ceilings									
Continuous false ceilings	•	•	•	•	•	•	•		
Heat exchanger									
Coil configuration	2 or 4	2 or 4	2 or 4	2 or 4	2	2 or 4	2 or 4	2	
Condensate drip tray	•		•			•		•	
Performance data									
Fresh air flow rate	[l/s]	5 – 70	3 – 45	5 – 50	5 – 70	12 – 80	12 – 25	10 – 78	278/555
	[m ³ /h]	18 – 252	10 – 160	18 – 180	10 – 252	43 – 288	43 – 90	36 – 281	1000/2000
Maximum cooling capacity [W]		1800	1600	1600	2500	1600	500	1000	27000
Maximum heating capacity [W]		1250	1250	1700	3000	1530	1200	500	10000

Induction units

Active Chilled Beams

Nominal width 300 mm

Type DID312

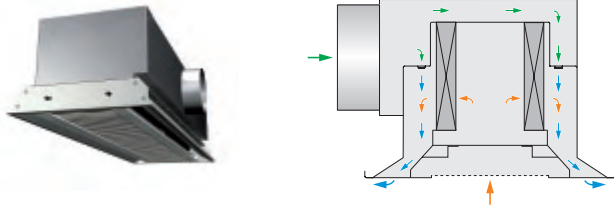

- Four options of induced air grille design
- Heat exchanger vertically mounted with condensate drip tray for low chilled water temperatures
- Side entry spigot for fresh air
- Supply-extract-air combination available

L: 900 – 3000 mm · H: 210 and 241 mm
 5 – 70 l/s · 18 – 252 m³/h fresh air
 Cooling capacity up to 1800 W
 Heating capacity up to 1250 W

Type DID300B

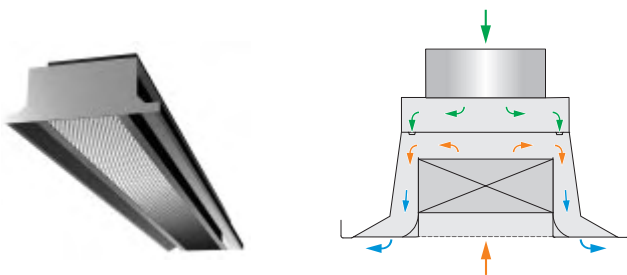

- Side or top entry spigot for fresh air
- Supply-extract-air combination available

L: 900 – 3000 mm · H: 210 mm
 3 – 45 l/s · 10 – 160 m³/h fresh air
 Cooling capacity up to 1600 W
 Heating capacity up to 1250 W

Nominal width size 600 mm

Type DID604

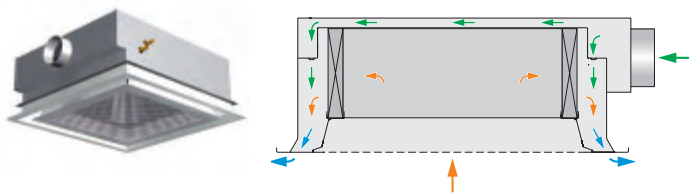

- Four-way air discharge
- Adjustable control blades to control the air discharge direction
- Side entry spigot for fresh air
- Heat exchanger vertically mounted with condensate drip tray for low chilled water temperatures

L: 600 and 1200 mm · H: 225 mm
 5 – 50 l/s · 18 – 180 m³/h fresh air
 Cooling capacity up to 1600 W
 Heating capacity up to 1700 W

Type DID632

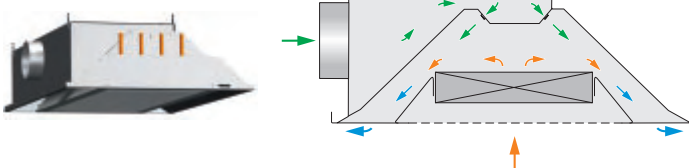

- Large cooling capacity
- Four options of induced air grille design
- Adjustable control blades to control the air discharge direction
- Adjustable induction nozzle configuration
- Side entry spigot for fresh air
- Supply-extract-air combination available

L: 900 – 3000 mm · H: 210 mm
 5 – 70 l/s · 18 – 252 m³/h fresh air
 Cooling capacity up to 2500 W
 Heating capacity up to 3000 W

Induction units

Active Chilled Beams

Freely suspended

Type AKV

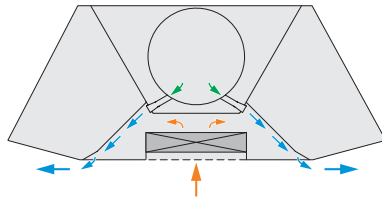

- Low height construction
- End mounted side entry spigot for fresh air
- Heat exchanger horizontal without condensate drip tray
- Project bespoke design

◀▶ L: 900 – 3000 mm · W: 300 and 500 mm
H: 175 and 200 mm

- ➡ 12 – 80 l/s · 43 – 288 m³/h fresh air
- ❄ Cooling capacity up to 1600 W
- 🔥 Heating capacity up to 1530 W

Circular

Type DID-R

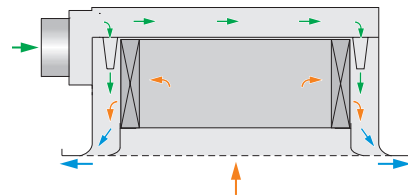

- Many design configurations available
- Circular or square face
- Side entry spigot for fresh air
- Heat exchanger vertically mounted with condensate drip tray for low chilled water temperatures
- Installation into false ceilings

◀▶ □: 593, 618, 598 and 623 mm, Ø: 598 mm

- ➡ 12 – 25 l/s · 43 – 252 m³/h fresh air
- ❄ Cooling capacity up to 500 W
- 🔥 Heating capacity up to 1200 W

One-way air discharge

Type DID-E

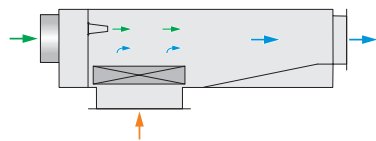

- Ideal for individual rooms in hotels or hospitals
- Induction and supply air grilles in various designs
- Side entry spigot for fresh air
- Heat exchanger horizontal without condensate drip tray
- Low height construction

◀▶ L: 550 and 614 mm · W: 900, 1200 and 1500 mm
H: 200 mm

- ➡ 10 – 78 l/s · 36 – 281 m³/h fresh air
- ❄ Cooling capacity up to 1000 W
- 🔥 Heating capacity up to 500 W

For installation in large height spaces

Type IDH

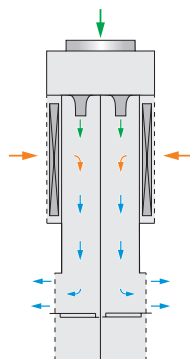

- One or two-way air discharge
- Adjustable discharge
- High capacity for large halls
- Top entry spigot for fresh air
- Heat exchanger vertically mounted with condensate drip tray for low chilled water temperatures
- Freely suspended installation

◀▶ L: 1500, 2000 and 2500 mm · W: 305 and 548 mm
H: 1405 mm

- ➡ up to 1670 l/s · 6000 m³/h fresh air
- ❄ Cooling capacity up to 27 kW
- 🔥 Heating capacity up to 10 kW

Multi-service-capability

Certain active chilled beams can provide additional functions. Particularly advantageous are the factory assembly and the wiring and piping of all components, which enable an easy and rapid installation on site of these plug and play systems.

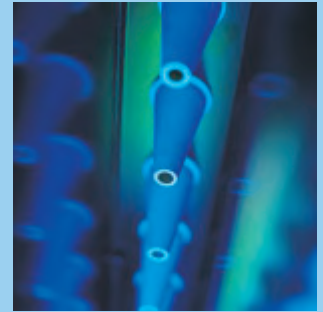
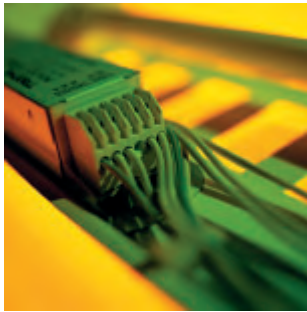

- Integration of lighting: various systems and performance
- Smoke detectors
- Sprinklers
- Loudspeakers
- Motion detectors
- Hidden integral cable trays

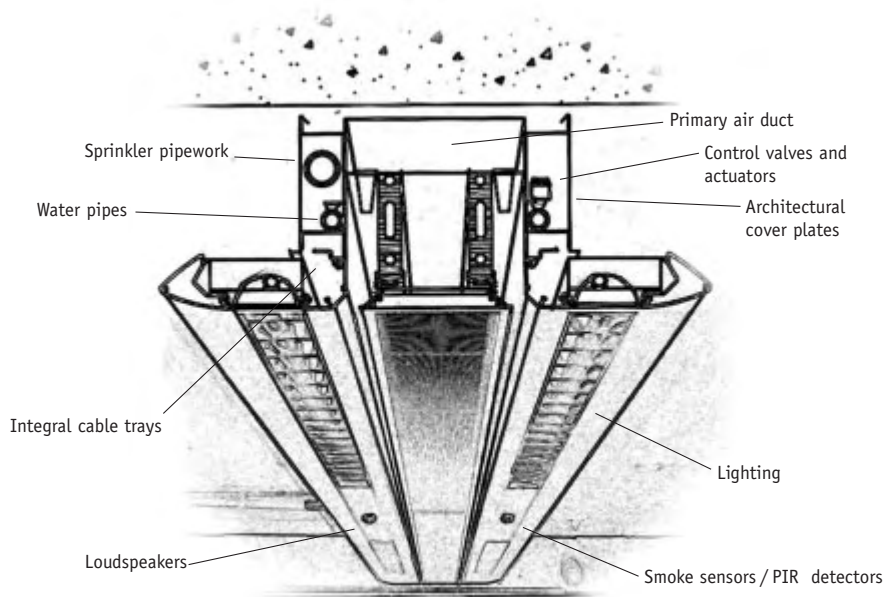

Advantages

- Shorter construction period
- Earlier amortisation of the investment for the owner
- Easy installation (plug and play)
- Significant reduction of interfaces on site
- Good quality of the system due to factory-assembly of the components

Induction units

Multi-service active chilled beams

Flush-mounted in the ceiling

Type DID600B-L

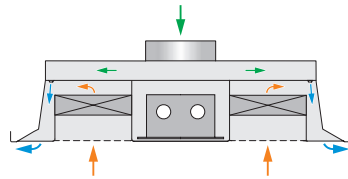

- Integrated linear light fittings
- Low height construction
- Top or side entry spigot for fresh air
- Heat exchanger horizontal
- Project bespoke dimensions

L: 1500 – 3000 mm · W: 593 mm · H: 210 mm
 3 – 43 l/s · 11 – 155 m³/h fresh air
 Cooling capacity up to 1610 W
 Heating capacity up to 1730 W

Freely suspended

Type MFD

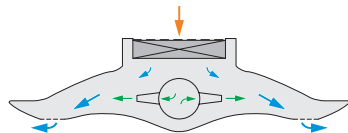

- Attractive design
- Heat exchanger horizontal
- Project bespoke multi-service integration
- Linear light fittings

L: 1980 mm · W: 800 mm · H: 213 mm
 14 – 22 l/s · 50 – 80 m³/h fresh air
 Cooling capacity up to 790 W
 Heating capacity up to 500 W

Type MSCB

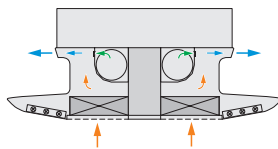
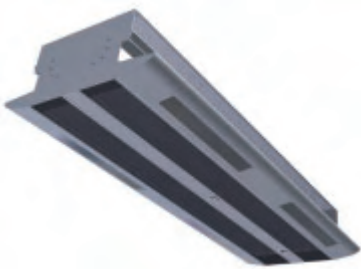

- Attractive design
- Cooling capacities to meet specific requirements
- Project bespoke multi-service integration
- Linear light fittings or halogen spotlights

L: 1500 – 5000 mm · W: 600 – 1200 mm · H: 440 mm
 3 – 45 l/s · 10 – 160 m³/h fresh air
 Cooling capacity up to 2750 W
 Heating capacity up to 2000 W

Induction units

Under sill induction units

Under sill induction units are suitable for a wide range of applications and outputs. The supply air is discharged into the room as a displacement or quasi displacement flow and thus creates a particularly comfortable indoor climate without draughts and with good indoor air quality.

Installation into under sill trim on internal or external walls allows for considerable freedom of design in terms of ceilings and floor.

The displacement flow principle results in comfortable and economic air conditioning with a low air flow rate because the air is very effectively supplied virtually directly to the room occupants.



Deutsches Hygiene-Museum, Dresden, Germany

© Deutsches Hygiene-Museum

Functional description

Under sill induction units are installed into under sill trim along an internal or external wall to provide a supply to the room. They provide fresh air (supply air) from a central air handling plant and local heat exchangers are used to deal with cooling and/or heat loads.

The supply air is discharged into a mixing chamber through nozzles. This induces secondary room air through the induction grille and through the heat exchanger into the mixing chamber. The subsequent mixed air flow is then discharged into the room as a displacement or quasi displacement flow system.

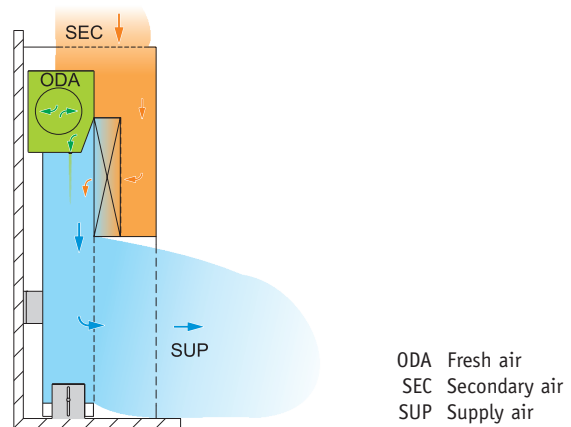

Displacement flow

The cooled supply air discharges horizontally into the room through a grille at low velocity (<0.5 m/s). In the process, the air velocity decreases. A "pool of supply air" characterised by low velocities and high air quality forms at low level in the room. The convection from people and other heat sources causes air from the supply air pool to rise and create comfortable conditions in the occupied zone.

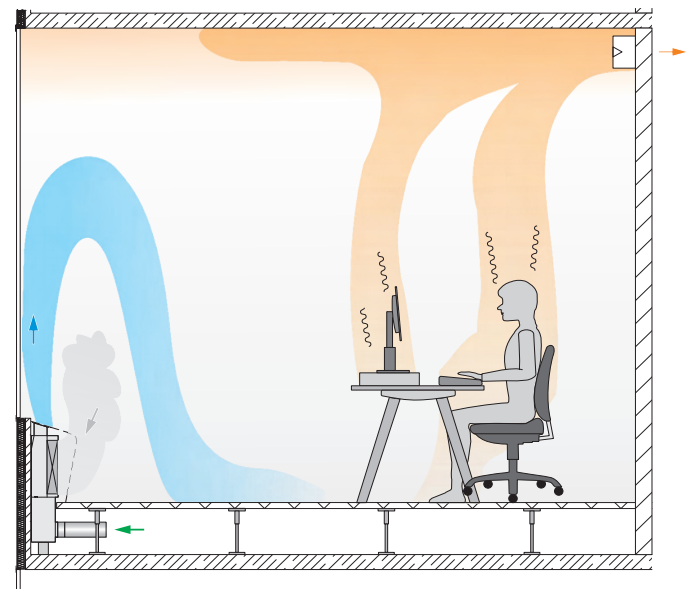

Quasi displacement flow

The cooled supply air initially discharges vertically or slightly inclined into the room through a grille at a mean velocity (1 to 1.5 m/s). Since cold air is heavier than hot air, the air flow direction reverses and the supply air flows locally towards the floor. There it forms a "pool of supply air" with properties as previously described.

Design information

General

Under sill induction units are mounted on an internal or external wall and covered with trim. The selection of the installation location is dependent on room use, architectural requirements and the boundaries of the occupied zone.

The only visible part of the induction unit are the supply and induced air grilles.

There are two options for the location of these grilles

- Both grilles vertical facing into the room
- One grille horizontal or near horizontal facing the ceiling and one grille vertical facing into the room

The grille is available in various constructions as a single grille or row of grilles (on the sill) made of aluminium, steel, or stainless steel.

Perforated plate grilles in various designs are also available.

Horizontal air discharge

In order for a displacement flow characteristic to occur without disturbance, an area of 1.0 to 1.5 m must remain free in front of the supply grille. This area cannot be part of the occupied zone.

In the case of the displacement flow, the extract air must always be removed near the ceiling.

Limitations of use

- The maximum room depth for this system is between 5 to 7 m. In larger rooms, under sill induction units would supply the occupied zone from two or more sides or an additional system is used.
- The supply air temperature difference in relation to the room temperature should not exceed -6 to -8 K.

Advantages

- Good air quality in the occupied zone
- Turbulence-free uniform flow with low velocities in the occupied zone
- Inconspicuous installation into an under sill trim
- Neither the ceiling layout nor the floor view is interrupted by grilles
- Almost no soiling of the air grille due to turbulence-free air discharge
- Structural cooling of the ceiling can also be used since the system does not require a false ceiling
- Due to the low noise generation, particularly suitable for use in rooms with ceiling structure cooling systems where sound absorption material at ceiling level cannot be installed
- Suited for the refurbishment of systems with high-pressure induction units

Sky-Office. Düsseldorf, Germany



Unit sizing

Effective temperature difference

In addition to the construction and material of the heat exchanger, the effective temperature difference is an important variable.

$$\Delta t_{RW} = \frac{(t_{KWV} + t_{KWR})}{2} - t_R$$

Δt_{RW} Effective temperature difference
 t_{KWV} Chilled water flow temperature
 t_{KWR} Chilled water return temperature
 t_R Room temperature

Conversion to other temperature differences

Manufacturer's data regarding thermal capacity is generally related to a specific temperature difference. The following formula is used for conversion to the project design temperature difference.

$$\dot{Q} \cong \dot{Q}_N \cdot \frac{\Delta t}{\Delta t_N}$$

\dot{Q} Thermal capacity (cooling or heating)
 \dot{Q}_N Heating capacity, manufacturer's data
 Δt Effective temperature difference, for design
 Δt_N Effective temperature difference, manufacturer's data

Water flow

Based on the equation below the required water flow rate can be easily calculated.

$$\dot{V}_W = \frac{\dot{Q}}{\Delta t_w} \cdot 0.86$$

\dot{V}_W Water flow rate in l/h
 \dot{Q} Thermal capacity (cooling or heating) in W
 Δt_w Water-side temperature difference

Correction factor for other water volume flow rates

The manufacturer's data usually applies to a fixed water flow rate. With a higher water flow, a higher thermal capacity can be achieved. Under certain circumstances, the required water flow is also reduced so that the actual capacity can be reduced.

Information regarding the correction factor can also be found in the unit documentation.

Sizing example

Parameters for unit sizing			
Parameters	Typical values	Example	Comments
Room temperature	22 to 26 °C	26 °C	
Room area (module 1.5 x 6.0 m)		9 m ²	
Cooling capacity		540 W	
Specific cooling capacity	40 up to 80 W/m ²	60 W/m ²	
Fresh air flow rate	5 to 8 (m ³ /h)/m ²	50 m ³ /h	
Fresh air temperature		16 °C	
Chilled water flow temperature	16 to 20 °C	16 °C	
Chilled water return temperature	18 to 23 °C	19 °C	
Results ¹⁾			
Cooling capacity of air		167 W	
Effective temperature difference	-10 to -4 K	-8.5 K	
Required cooling capacity of water		373 W	
Cooling capacity at -10 K		439 W	
Chilled water flow	50 to 250 l/h	107 l/h	
Cooling capacity at -10 K and 110 l/h		439 W	/ 1,0 correction to 110 l/h
Selected : QLI-2-G/1200			Nozzle type: G
Nominal cooling capacity	200 to 1100 W	440 W	at -10 K, manufacturer's data
Project cooling capacity		541 W	374 + 167
Air velocity beyond 1.5 m distance	0.15 to 0.22 m/s	0.16 m/s	Height: 0.10 m
Water-side pressure drop	3.0 to 4.5 kPa	3.8 kPa	
Sound pressure level	to 30 dB(A)	<20 dB (A)	with 6 dB room attenuation

¹ Calculated with the TROX design programme

Induction units

Under sill induction units

Displacement flow

Type QLI

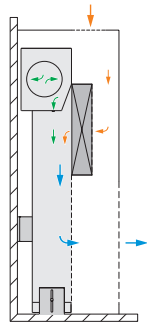

- End mounted side entry spigot for fresh air
- Heat exchanger vertically mounted with condensate drip tray for low chilled water temperatures

◀▶ W: 900, 1200 and 1500 mm · H: 730 mm · D: 200 mm

⌚ 4 – 50 l/s · 14 – 180 m³/h fresh air

❄ Cooling capacity up to 1100 W

🔥 Heating capacity up to 1730 W

Special mixed and displacement flow

Type IDB

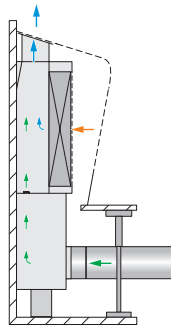

- Side entry spigot for fresh air in false floor
- With regenerative coarse dust filter
- Project bespoke dimensions

◀▶ W: 1200 mm · H: 567 mm · D: 134 mm

⌚ 4 – 40 l/s · 14 – 144 m³/h fresh air

❄ Cooling capacity up to 800 W

🔥 Heating capacity up to 1000 W

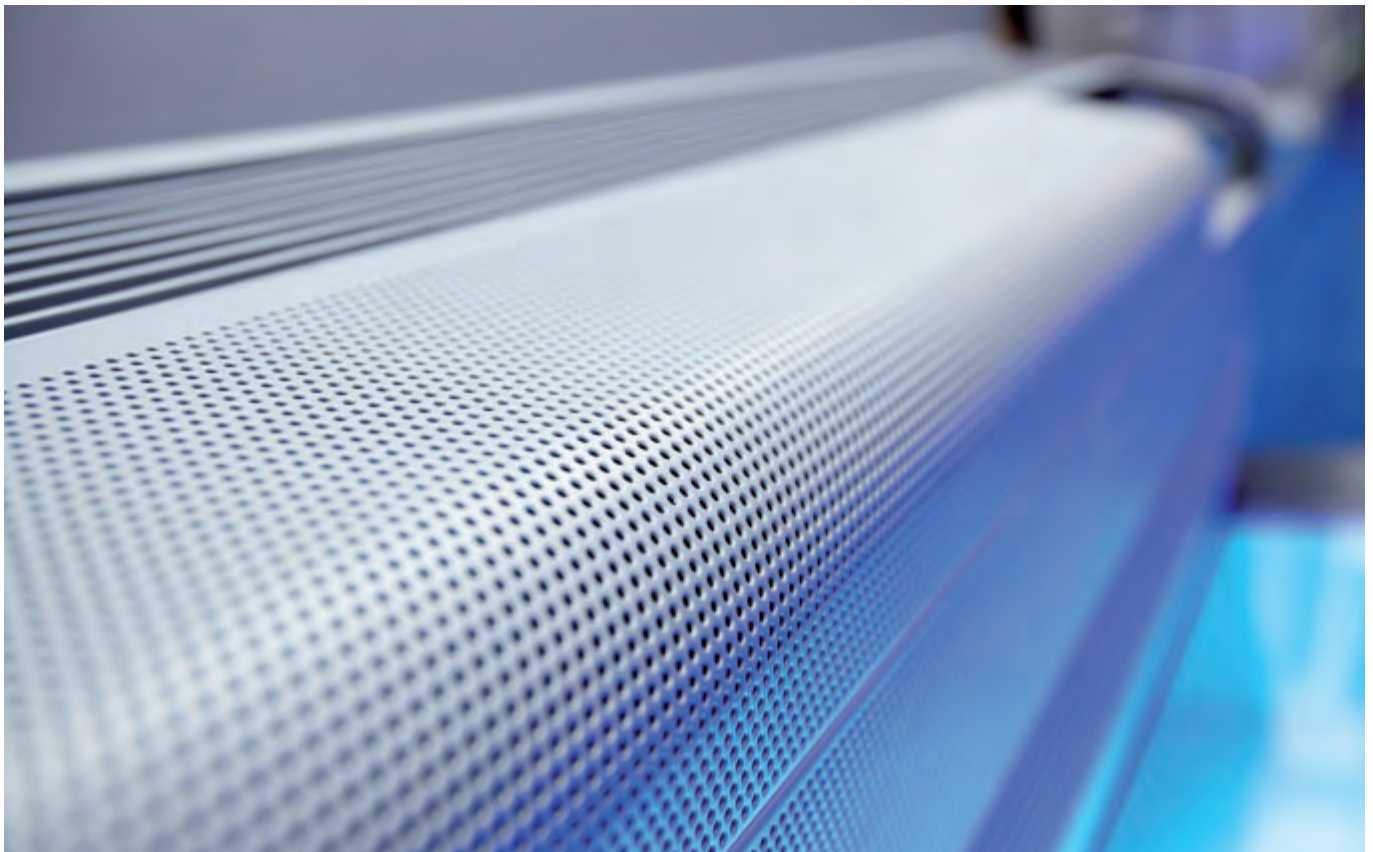

Induction units

Under floor induction units

Under floor induction units provide an optimum solution for the ventilation of the perimeter zones especially in buildings with ceiling to floor glazing. In modern office buildings the use of false floors is state of art, thus the use of this form of ventilation technology makes sense in these situations.

Due to using a location beneath the window surface the thermal effect of the window inner surface is reduced resulting in a comfortable environment throughout the year.



Office am See, Bregenz, Austria

Functional description

Under floor induction units are installed under the false floor adjacent to the façade. They provide the perimeter zones or rooms with fresh air (supply air) from a central air handling plant and have local heat exchangers to deal with cooling and/or heating loads.

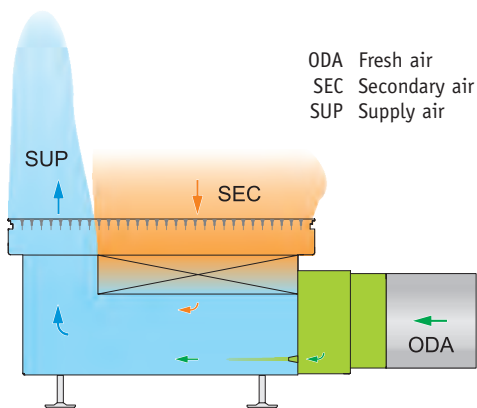

View BID

The supply air is discharged into a mixing chamber through nozzles. This induces secondary room air through the floor grille and through the heat exchanger into the mixing chamber. The subsequent mixed air flow is then discharged vertically into the room through a grille at low velocity (0.7 m/s).

European Investment Bank, Luxembourg



Advantages

- Good air quality in the occupied zone due to displacement ventilation
- Turbulence-free uniform flow with low velocities in the occupied zone
- Completely free interior, does not impinge on full height glazing systems
- Inconspicuous integration of units, no drawbacks to the comfort of the occupier
- Does not require a false ceiling
- Minimised thermal influence of the window surface on comfort:
 - Cool pane in the summer
 - Temperature-controlled pane in the winter
- Can be combined with ceiling structural cooling
- Due to the low noise generation, particularly suitable for use in rooms with ceiling structure cooling systems where sound absorption material at ceiling level cannot be installed.

Induction units

Under floor induction units

Cooling operation

The horizontal air discharge into the room takes place similar to displacement ventilation. The cooled supply air initially discharges upwards. Since cold air is heavier than warm air, the air flow direction reverses and the supply air flows locally towards the floor. In the process, the air velocity decreases. A "pool of supply air" characterised by low air velocities and good air quality forms at low level within the room. The convection from people and other heat sources causes air from "the supply air pool" to rise and create comfortable conditions in the occupied zone. A part of the air discharge from the grille is already heated by the window surface and conducted further up the window. In the interest of occupant comfort, this effect is desirable since the surface temperature of the pane thus remains low.

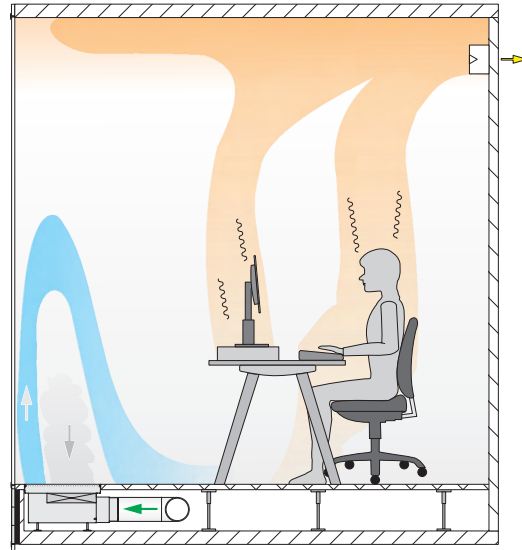

Heating operation

The supply air, which is heated or at room temperature, discharges vertically upwards. With an increasing, positive temperature difference between the supply air and local air, the air flow can no longer return to the floor and as a result a mixed flow air distribution is set up in the space. The warm air stream up the window surface has a positive influence on the perception of the occupants because the surface temperature of the window surface increases. The uncomfortable feeling that arises near cold window surfaces (cold radiation) fails to materialise.

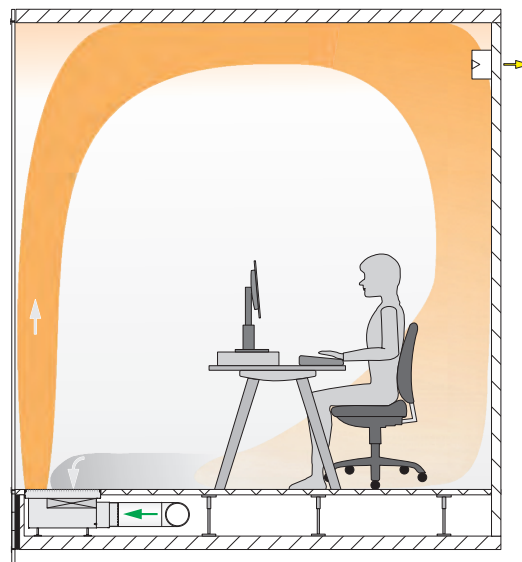

Heating operation without supply air

In heating operation without supply air (operating mode: stand-by), the under floor induction unit operates as a static heater. The air in the heat exchanger is heated and rises due to convection. The air adjacent to the window surface can only fall down to the heat exchanger. Thus the heat loss from the window surface is directly compensated for.

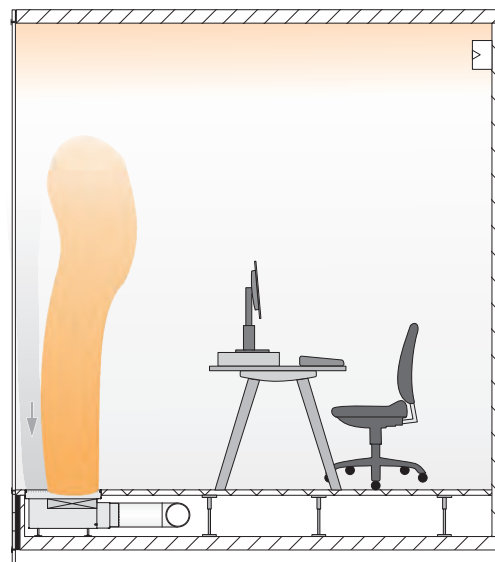

Design information

General

Since under floor induction units are directly adjacent to the façade, the unit width is selected dependent on the modular pitch of the façade. This particularly applies to buildings with full height glazing. The units are arranged between any concrete pillars located along the external wall. Under floor induction units can be spaced between 1.20 to 1.80 m. The only visible component of under floor induction units is the linear floor grille which can have blades parallel or perpendicular to the facade. Other options are single grilles, a row of grilles, and roll down grilles made of aluminium, steel, or stainless steel.

Horizontal air discharge

In order for a displacement flow characteristic to occur without disturbance, an area of 1.0 to 1.5 m must remain free in front of the supply grille. This area cannot be considered part of the occupied zone. In the case of the displacement flow, the extract air must always be removed near the ceiling.

Limitations of use

The maximum room depth for this system is between 5 to 7 m. In larger rooms, under floor induction units would supply the perimeter zone, while a further system, such as active chilled beams, supply the internal zone.

Sizing example

Parameters for unit sizing			
Parameters	Typical values	Example	Comments
Room temperature	22 to 26 °C	26 °C	
Room area (module 1.5 x 6.0 m)			
Cooling capacity		450 W	
Specific cooling capacity	40 up to 70 W/m ²	50 W/m ²	
Fresh air flow rate	5 to 8 (m ³ /h)/m ²	50 m ³ /h	
Fresh air temperature		16 °C	
Chilled water flow temperature	16 to 20 °C	16 °C	
Chilled water return temperature	18 to 23 °C	18 °C	
Results ¹⁾			
Cooling capacity of air		167 W	
Effective temperature difference	-10 to -4 K	-9 K	
Required cooling capacity of water		283 W	
Cooling capacity at -10 K		300 W	
Chilled water flow	50 to 250 l/h	122 l/h	
Cooling capacity at -10 K and 110 l/h		294 W	/ 1.02 correction to 110 l/h
Selected: BID-4-U/1250x900x98			Nozzle type: U
Nominal cooling capacity	200 to 1000 W	357 W	at -10 K, manufacturer's data
Project cooling capacity		511 W	344 + 167
Air velocity beyond 1.5 m distance	0.15 to 0.22 m/s	0.11 m/s	Height: 0.10 m
Water-side pressure drop	3.0 to 4.5 kPa	5.5 kPa	
Sound pressure level	to 40 dB(A)	<20 dB (A)	with 6 dB room attenuation

1 Calculated with the TROX design programme

Unit sizing

Effective temperature difference

In addition to the construction and material of the heat exchanger, the effective temperature difference is an important variable.

$$\Delta t_{RW} = \frac{(t_{KWV} + t_{KWR})}{2} - t_R$$

Δt_{RW} Effective temperature difference
 t_{KWV} Chilled water flow temperature
 t_{KWR} Chilled water return temperature
 t_R Room temperature

Conversion to other temperature differences

Manufacturer's data regarding thermal capacity is generally related to a specific temperature difference. The following formula is used for conversion to the project design temperature difference.

$$\dot{Q} \cong \dot{Q}_N \cdot \frac{\Delta t}{\Delta t_N}$$

\dot{Q} Thermal capacity (cooling or heating)
 \dot{Q}_N Heating capacity, manufacturer's data
 Δt Effective temperature difference, for design
 Δt_N Effective temperature difference, manufacturer's data

Induction units

Under floor induction units

Type BID

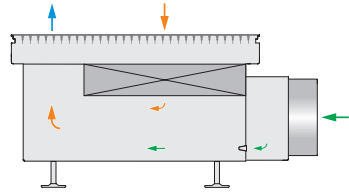
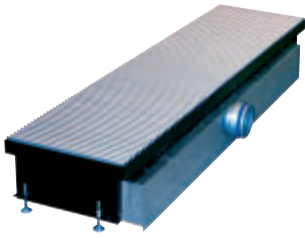

- Rectangular floor grille in various configurations and materials
- Low construction height
- Project bespoke dimensions

◀▶ W: 1100 – 1849 mm · H: 191 mm · D: 404 mm

⌚ 4 – 40 l/s · 14 – 144 m³/h fresh air

❄ Cooling capacity up to 1030 W

🔥 Heating capacity up to 1225 W



European Investment Bank, Luxembourg



Light-Tower, Frankfurt/M, Germany

Façade ventilation units

Decentralising ventilation systems and mounting them into or onto the façade brings advantages in terms of design, comfort, and economics to many projects. The space requirement for plant rooms and ducts is no longer required or reduced drastically. This has considerable influence on the slab to slab room height and thus on the entire building investment.

For new construction projects, innovative project-specific ventilation systems that offer great flexibility and energy-efficiency are available using façade ventilation units. Since façade ventilation units require no central air handling plant, they are often the only and ideal solution for the refurbishment of an existing building with ventilation and air conditioning systems.



Air flow measurement

Functional description

Façade ventilation units can offer various decentralised air handling functions. They are arranged in or on external walls or façades. The units allow noise controlled air handling from the inside to the outside or vice versa using the shortest possible path. A duct distribution system is not required.

Façade ventilation units are usually project-specific solutions based on sophisticated, proven functional units. For the selection and understanding of these units, the following criteria are very important: the required concept for the decentralised system, the range of functions required and the installation location. Up to now, based on a combination of the above criteria, numerous projects have been fitted out with façade ventilation units. For the future even more options will be available.

Decentralised ventilation systems

Rooms can be ventilated solely using decentralised façade ventilation units, or the units can be used to supplement central plant systems.

Functions

The range of functions available in façade ventilation units can be from static inflow/outflow units to mini powered air handling units. Innovative technology is also available with units using phase change materials.

In the following, the unit options are described in detail, including the functional modular inserts and components available.

Installation location

The installation locations are primarily divided into under sill and under floor. Under sill units can be installed below the sill (below the window), in front of the sill, or also on top of or to the side of the window. Under floor units are installed into the false floor void adjacent to the façade. They are an ideal solution for projects with full height glazing. Façade ventilation units can also be integrated into the actual façade. The off site fabrication of the façade element plus the ventilation unit offers improved site logistics and hence very good quality and reduction in costs.

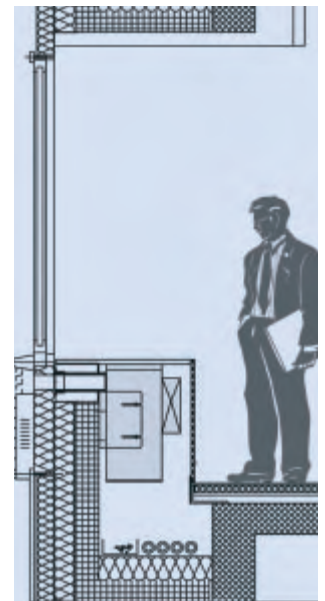

Advantages

- Good occupant acceptance and satisfaction:
 - Individual control
 - Opening windows can be used
- Good level of energy efficiency:
 - System shuts down when not in use or when windows are opened
 - Heat recovery available
- Low energy requirement as air is supplied to the room at low speed and using the shortest possible route
- As a result very good fan efficiencies are achieved, low specific fan powers (SFP)
- Very efficient use of space as central air handling plant and ductwork distribution systems are not required
- Often the only practical method to refurbish a building with a mechanical ventilation/air conditioning system at an acceptable cost
- Simple recording of services costs and simplified billing for multi rental spaces

Decentralised ventilation systems

Decentralised supply air – Centralised extract air

Façade ventilation units maintain the air quality in rooms by supplying fresh air to the room. In the simplest case, static inflow units let as much air flow into the room as will be removed by the powered extract air system. Supply air units that have a fan allow controlled ventilation with a regulated or limited fresh air flow rate. The fresh air can also be tempered and filtered.

The extract air is removed at floor level by room or groups of room using a central extract air system.

Application example: refurbishment for the improvement of the indoor air quality using the existing extract air system.

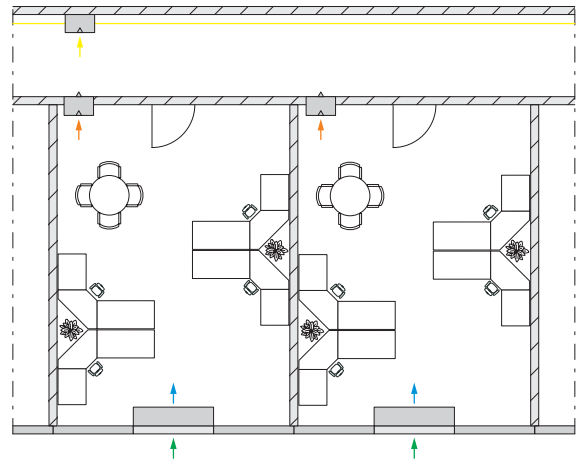

Decentralised supply air and extract air

The entire ventilation is decentralised. A very good indoor air quality is achieved using façade ventilation units since they supply conditioned fresh air directly to the room. Air treatment and air handling are combined in a single unit.

Air treatment is performed to meet the project-specific requirements and conditions. Even the room extract air is exhausted to the outside using the façade ventilation unit. For this purpose, combined supply and extract air units are available.

Application example: New construction or refurbishment with decentralised ventilation technology.

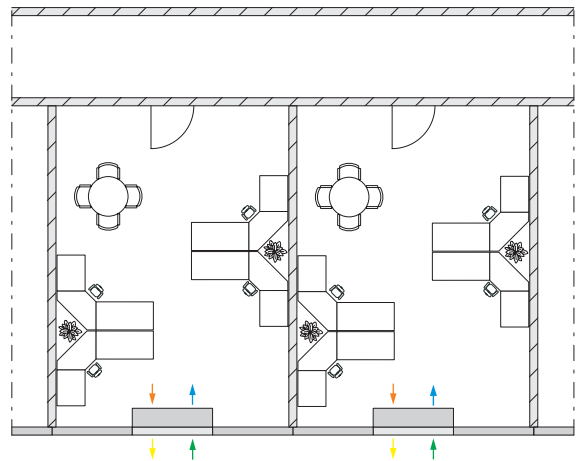

Secondary air

Rooms and zones with high thermal loads are only supplied with the fresh air flow rate required to maintain the air quality. Any heating or cooling capacities required beyond this can be provided with secondary/recirculation air units. They can effectively supplement both decentralised and centralised ventilation systems.

Application example: New construction, refurbishment, or retrofit.

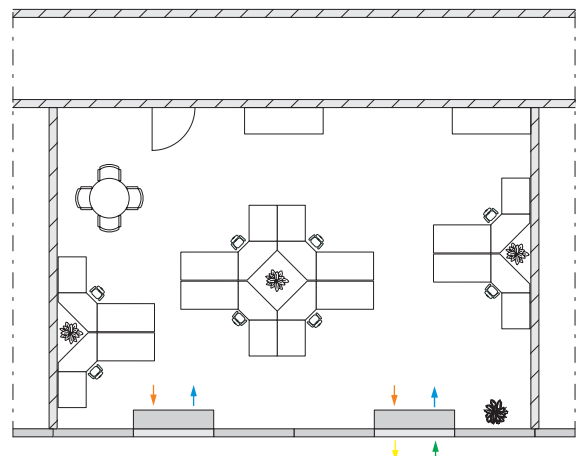

Large zones

For the ventilation of large zones, a combination of façade ventilation units with, for example, active chilled beams, is a good solution.

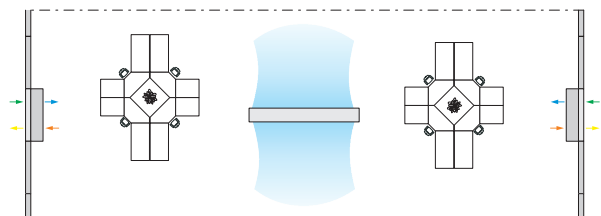

Functions

Supply air module

The supply air fan provides fresh air, which is filtered and tempered and is then discharged in the room.

- **Non-return damper**
Depending on the wind direction, underpressure may prevail on one side of the building. This can result in reverse flow of condition air in the unit to the outside. To prevent this from occurring a non-return damper is fitted.
- **Shut-off damper**
In case the unit is switched off, a spring return actuator closes the shut-off damper and thus prevents uncontrolled air flow that would otherwise heat up the building very quickly in summer and cool it down in the winter.
- **Fine dust filter**
Mechanical air treatment takes place using a filter to extract fine dust. The location of a filter in front of the fan protects both the fan and the downstream components, particularly the heat exchanger from contamination. As a result good air quality supply air is provided for the occupants.
- **Flow rate controllers**
Due to the filter and varying wind pressure on the façade, differential pressures can alter the air change rate. Use of a flow rate controller prevents the required air flow rate from being exceeded.
- **Fan**
To provide the air supply an energy efficient low noise centrifugal fan is used.
- **Sound attenuator**
The fan noise and outside noise are efficiently reduced in the sound attenuator despite its small size. The particularly low fan sound power level allows the use of units even in projects which require low noise levels.



Heat exchanger module

The heat exchanger unit includes cooling and/or heating coils, control valves with actuator, shut-off valves, and a supply air temperature sensor. A condensate drip tray collects any condensate that occurs.

The thermal loads of the room are dealt with by the coils. In the heating coil, the temperature of the air increases while the absolute humidity remains constant. The cooling performance of the coil depends on the chilled water flow temperature. If this temperature is above the dew point of the fresh air, a so-called dry (sensible) cooling takes place in which the moisture content of the air remains unchanged. On falling below dew point temperature a portion of the moisture in the air condenses on to the cooling coil (latent cooling), thus removing additional heat from the air.

Façade ventilation units are mostly designed for dry cooling. Despite this, the units have a condensate drip tray that can collect any condensate should the air temperature temporarily fall below the dew point. Any condensate thus collected will evaporate over time.

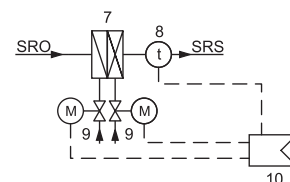
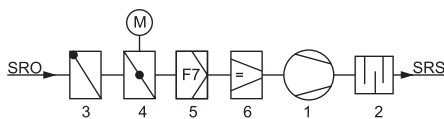

- | | |
|-----------------------------|----------------------------|
| 1 Fan | 7 Heat exchanger |
| 2 Sound attenuator | 8 Temperature sensor |
| 3 Backdraught damper | 9 Motorised control valve |
| 4 Motorised shut-off damper | 10 FSL-CONTROL |
| 5 Filter | SRO Fresh air single room |
| 6 Flow rate controller | SRS Supply air single room |

Exhaust air module

The exhaust air fan removes the air from the room and discharges it to outside.

- Coarse dust filter
A coarse dust filter protects the fan and heat exchanger from contamination.
- Sound attenuator
The fan noise is efficiently reduced in the sound attenuator. The particularly low fan sound power level allows the use of units even in projects which require low noise levels.
- Fan
To provide the air supply an energy efficient low noise centrifugal fan is used.
- Non-return damper
In case of wind pressure, fresh air that has not been treated may get into the room through the unit. This reversal of the air flow direction is prevented by fitting a non-return damper.
- Shut-off damper
In case the unit is switched off, a spring return actuator closes the shut-off damper and thus prevents uncontrolled air flows that would otherwise heat up the building very quickly in summer and cool it down in the winter.

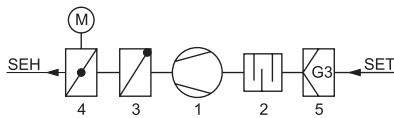

Heat recovery

With a heat exchanger for heat recovery, a portion of the heat in the exhaust air is transferred to the fresh air. As appropriate from an energy standpoint, during transition periods and to avoid freezing in the heat recovery unit a damper is used to bypass the heat recovery unit.

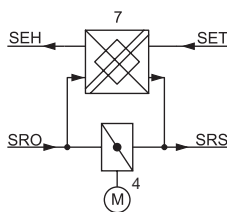

- | | |
|-----------------------------|-------------------------------|
| 1 Fan | 7 Heat exchanger |
| 2 Sound attenuator | SRO - Fresh air single room |
| 3 Backdraught damper | SRS - Supply air single room |
| 4 Motorised shut-off damper | SEH - Exhaust air single room |
| 5 Filter | SET - Extract air single room |
| 6 Flow rate controller | SEC - Secondary air |

Secondary air module

To deal with higher thermal loads, room (secondary) air is recirculated, it passes through the heat exchanger together with the fresh air. As the total air flow is increased so does the heating or cooling capacity. To control the capacity, the supply air fan can either be multi stage or have direct variable speed control.

- Secondary air mixing
As the cooling or heating load increases, the fan speed and thus the supply air flow rate increase. When the supply air flow rate is greater than the fresh air flow rate, the difference is made up with room (secondary) air.
A system powered flow rate controller regulates the secondary air flow rate.
- Secondary air operation
In unoccupied rooms the use of standby operation with no fresh air is an attractive proposition. For temperature control in the room, only secondary (room) air is circulated through the heat exchanger.
- Recirculation unit
Secondary air units have no fresh air connection; they are intended only for recirculation of secondary air to deal with thermal loads.

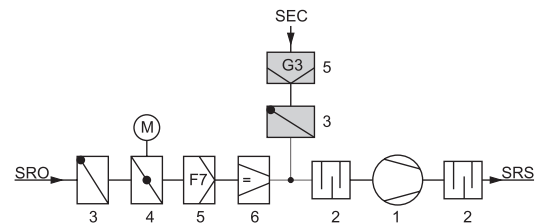

Capricorn-Building, Düsseldorf, Germany

Phase change material (PCM) module

In daytime operation, the warm fresh air passes through a PCM storage unit, where it is cooled and introduced into the room. This cooling process is effective until the previously solid PCM in the storage unit has liquefied as a result of the heat it has absorbed. In nighttime operation, the colder outdoor air passes through the unit and the PCM solidifies again and can thus be re-used to cool the room during the day.

Depending on the design of the latent-heat storage unit, a pleasant room temperature can be ensured for up to 10 hours during the following day.

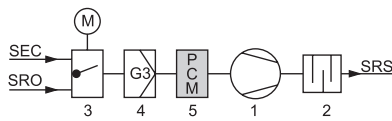

The façade ventilation unit with PCM module obtains the fresh air through an opening in the façade and discharges it into the room. In case of very high outside temperatures, the mixing of secondary air or sole secondary air operation means that the PCM in the storage unit melts at a slower rate and the storage unit does not discharge so quickly.

In summer, during the nighttime use of the storage unit, the building structure is also cooled (night cooling). This means that the unit can be used in rooms with a cooling load of up to 60 W/m².

- | | |
|---------------------|----------------------------|
| 1 Fan | 5 PCM-Stack |
| 2 Sound attenuator | SRO Fresh air single room |
| 3 Changeover damper | SRS Supply air single room |
| 4 Filter | SEC Secondary air |

Cooling naturally with Phase Change Materials (PCM)

PCM – the energy of phase change

If heat (energy) is supplied to or removed from a substance, the temperature of the substance changes or the substance changes its aggregate state (solid, liquid, or gaseous) at certain temperatures (melting and boiling point) without further temperature changes. All substances and materials have this property, but at different temperatures and pressures. For ventilation technology, paraffin or salt hydrates with melting points between 20 and 25°C can be used as PCMs. In case of a change of aggregate state, a large volume of heat, the so-called latent heat, can be stored or released at a constant temperature. A small temperature difference suffices to bring about the change of the aggregate state. Supposing that the mass of one kilogramme of concrete is cooled by 10 K at normal room temperature during nighttime cooldown, this thermal mass has the cooling potential to draw 10 kJ heat from the room during the day.

Since the PCM changes its aggregate state from liquid to solid under the same conditions during nighttime cooldown, this gives rise to a cooling potential of approx. 190 kJ (approx. 0.05 kWh) per kilogramme, i.e. 19 times greater than concrete.

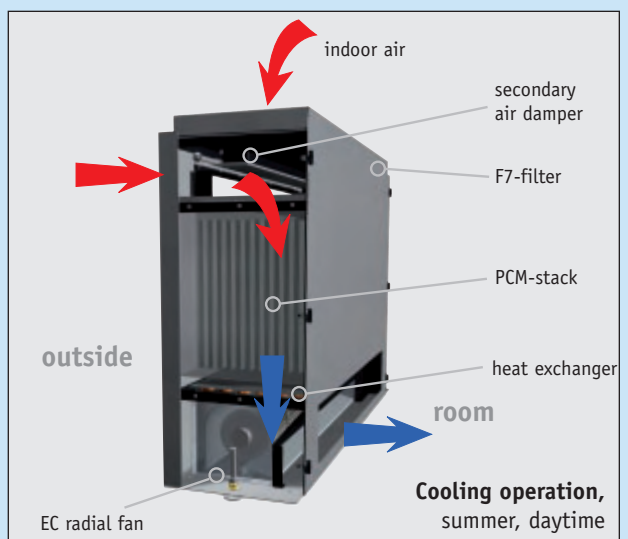
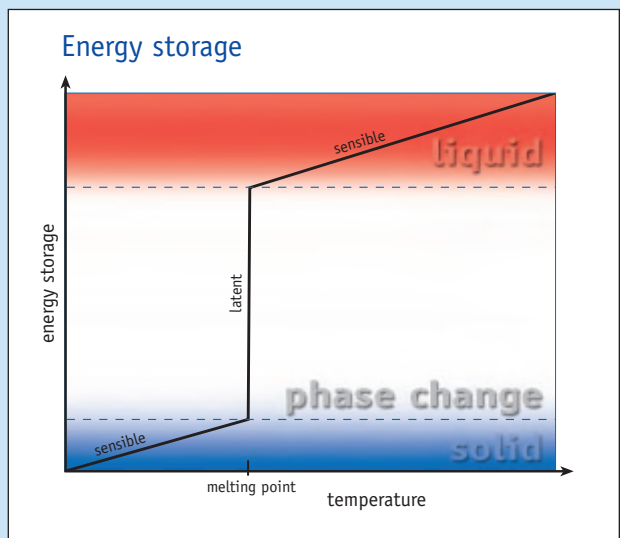

Control

Depending on the range of functions in the selected façade ventilation unit and the overall control engineering design, complementary control and regulation functions should be installed. Various operating modes for energy saving should also be taken into consideration, as well as the compatibility with the general building control systems.

FSL-CONTROL provides an individual room control system that is ideally tailored to the façade ventilation units. The controller has the necessary electronics to connect and communicate with control panels, temperature sensors, and actuators and the software to regulate the parameters listed below.

Room temperature

The room temperature is mainly regulated by controlling the water valves associated with the heat exchangers. Secondary air units are operated with variable supply air. In addition, the fan speed is controlled in steps.

Supply air temperature

Particularly critical comfort requirements can be fulfilled using a regulated or limited supply air temperature. In the form of a cascade control system, the supply air temperature setpoint follows the requirement for regulating the room temperature.

Fresh air flow rate

The supply air fan and its operational speed is selected based on the fresh air flow rate. Separate flow rate control is not required. The supply air fan usually has three selectable speeds depending on requirement. The lowest fan speed is based on the required minimum fresh air flow rate.



*FSL-CONTROL
Control panel*

FSL-CONTROL components

- LON-Controller
- Control panels
- Water valves for hot and chilled water
- Valve actuators
- Supply air temperature sensors

FSL-CONTROL modes

- Comfort mode
The room temperature is regulated to a setpoint value selected by the occupant of the room.
- Standby
The setpoint value is raised or lowered.
- Unoccupied
The room temperature is not regulated. Frost and overheating protection functions continue to be active. Supply air units with secondary air function switch to secondary air operation.

FSL-CONTROL – Safety functions

- Icing protection of the heat recovery unit
- Frost protection of the heat exchanger
- Overheating and frost control in the building

Office Building Feldbergstraße, Frankfurt/M, Germany



Design information

Unit options

Function	Unit options					
	ZUL	ABL	ZAB	ZAS	ZUS	SEK
Modules						
Supply air	•		•	•	•	
Extract air		•	•	•		
Secondary air				•	•	•
Additional modules						
Heat exchanger unit	•		•	•	•	•
Heat recovery			•	•		
Phase change material	•		•	•	•	•

Design

Façade ventilation units are generally project-specific solutions that are designed to meet conditions in an existing building or the specification for a new build. Thus the scope for design is virtually unlimited. Under sill units are clad by the customer. The supply and extract air grilles are available in various designs. The extract air grille can be located below or on the sill. On under floor units, only the linear floor grille is visible, which can have blades parallel or perpendicular to the façade. Other options are single grilles, a row of grilles, and roll down grilles made of aluminium, steel, or stainless steel.

The façade as an interface

The size, arrangement, and design of the fresh and exhaust air openings in the façade require early coordination with the architect, façade designer, specialist mechanical services consultant, and unit manufacturer.

- **Installation**
The distance between the fresh and exhaust air openings should be as large as possible to prevent a “short circuit” between the exhaust and fresh air. The exhaust air should be discharged with high velocity and directed away from the intake opening. This also relates to units serving adjacent rooms.
- **Construction**
A permanently sealed connection of the façade ventilation unit to the façade is important. In addition, the unit must have a thermal break between the unit and the external surface of the façade.
- **Weather protection**
Protection against ingress of driving rain can be achieved by either using external weather louvers or detail design of the air entry path. The velocity in the façade inlet should not exceed 2.0 m/s. The base of the inlet should have an adequate slope to the outside to ensure water drainage during extreme weather.

Horizontal air discharge

Independent of the installation location, façade ventilation units discharge air into the room in the form of a displacement flow. Higher air velocities (up to 2 m/s) occur through the unit cladding or the floor grille. However, the velocity subsequently reduces rapidly due to the induction process, such that displacement flow occurs in the occupied zone. In order for a displacement flow characteristic to occur without disturbance, an area of 1.0 to 1.5 m must remain free in front of the unit. This area cannot be part of the occupied zone.

Limitations of use

- If the relative humidity is to remain constant within close limits, this is only possible at great expense.
- Rooms with a large number of people and a limited façade area cannot be sufficiently dealt with by façade ventilation units alone.
- The maximum room depth amounts to 5 to 7 m. In larger rooms, façade ventilation units supply the perimeter zone, while another system, such as active chilled beams, supply the internal zone.
- Façade ventilation units are not suitable for the air conditioning of clean rooms.

Laimer Würfel, München, Germany



Unit sizing

Project-specific values and functions

Façade ventilation units are generally designed and sized based on the requirements and conditions of a project. The units cannot be selected from a range of standard sizes as is normal with many products, but are bespoke requiring technical clarification by the manufacturer. The essential data required to define unit performance and functions is listed below.

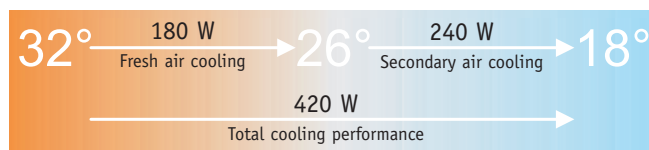

Cooling and heating loads

The supply air flow rate and the difference between supply air temperature and room temperature define the cooling or heating capacity discharged into the room to deal with the thermal loads.

$$\dot{Q} = \dot{V} \cdot (t_{\text{SUP}} - t_{\text{R}}) \cdot a$$

Cooling and heating capacities

The difference between the supply air temperature and the fresh air temperature should be taken into consideration when sizing the heat exchanger, chiller, and boiler.

$$\dot{Q} = \dot{V} \cdot (t_{\text{SUP}} - t_{\text{ODA}} - \Delta t_{\text{F}}) \cdot a$$

\dot{V}	a
l/s	1,20
m ³ /h	0,33

- \dot{Q} Thermal capacity (cooling or heating) in W
- \dot{V} Supply air flow rate in l/s or m³/h
- t_{SUP} Supply air temperature
- t_{R} Room temperature
- t_{ODA} Outdoor temperature
- Δt_{F} Temperature increase on the surface of the façade

Sizing example

Parameter	Project Traungasse
Required unit performance	
Fresh air flow rate	up to 120 m ³ /h
Cooling capacity	up to 780/320 W
Heating capacity	up to 1780/420 W
Maximum sound power level	45 dB(A)
Noise reduction outside to inside	50 to 55 dB
Maximum dimensions	W: 1200 mm · H: 630 mm · D: 320 mm
Operating data	
Room temperature (summer / winter)	26°C / 21°C
Outdoor temperature (summer / winter)	32°C / -12°C
Hot water temperature (flow / return)	60°C / 40°C
Chilled water temperature (flow / return)	16°C / 19°C
Range of functions	
Installation location	Sill
Unit type	Supply and extract air unit (ZAB)
Fresh air filter	F7
Extract air filter	G3
Fan	Yes
Flow rate controller	Yes
Heat exchanger	Four pipe coil
Heat recovery with bypass damper	Yes
Shut-off damper with spring return actuator	Yes
Non-return damper	Yes
FSL-CONTROL controller	Yes
Hydraulic connections (valves, valve actuators, compression couplings)	Yes
Flexible hoses	No
Air grille or roll-down grille (steel / stainless steel / aluminium)	Only in the case of under floor units
Steam humidification	No
Phase change material	No

Façade ventilation units

Under sill units

In-flow or out-flow units

Type FSL-B-60

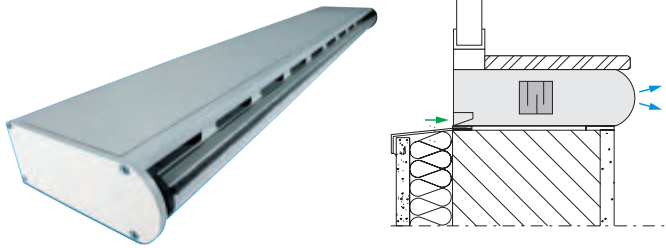

- Natural ventilation with good acoustic performance
- Installation below or above a window or in walls
- Uncontrolled ventilation
- Manually operated air discharge control cylinder
- Lined with thermal/acoustic material

W: 200 – 3000 mm · H: 60 mm · D: 140 – 600 mm
 3 – 42 l/s · 10 – 150 m³/h at 12 Pa differential pressure

In-flow or out-flow units Supply or extract air units

Type FSL-B-100

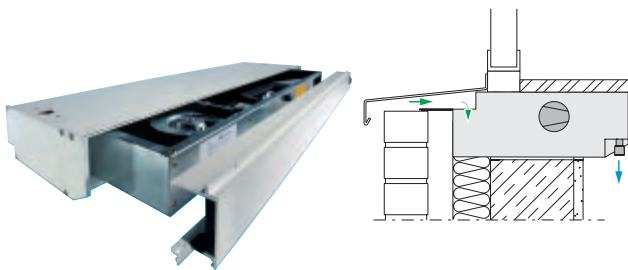

- Natural or mechanical ventilation with good acoustic performance
- Project bespoke construction
- Installation below, above or to the side of the window
- Modular design:
Base casing for installation during construction phase
Modular inserts for subsequent fitting
- Lined with thermal/acoustic material
- Fine dust filter available

W: 1000 – 3000 mm · H: 100 mm · D: 230 – 600 mm
 8 – 22 l/s · 30 – 80 m³/h fresh air

Supply and extract air units (ZAB)

Type FSL-B-190

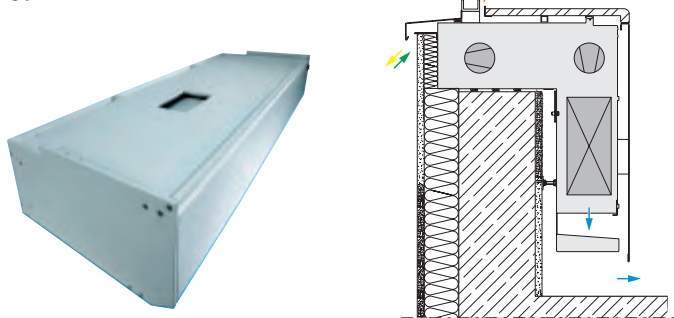

- Mechanical ventilation with good acoustic performance
- With heat recovery
- Option with heat exchanger for heating and cooling
- Under sill installation or installation under a window
- Modular design:
Base casing for installation during construction phase
Modular inserts for subsequent fitting
- Can also provide static heating

W: 1200 mm · H: 190 mm · D: 450 – 600 mm
 17 – 33 l/s · 60 – 120 m³/h fresh air
 Cooling capacity up to 560 W
 Heating capacity up to 1735 W

Supply air units with phase change material

Type FSL-B-PCM

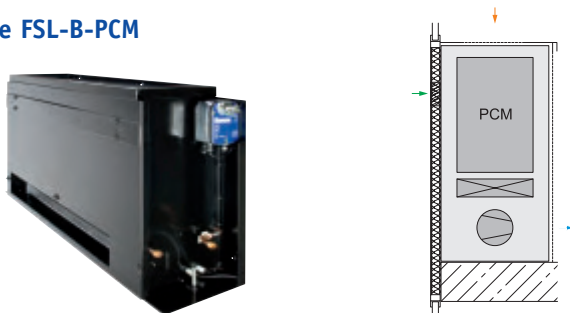

- Supply air and recirculated secondary air modes possible
- CO₂-neutral cooling without refrigerants
- With air heater
- Project bespoke dimensions
- Ideal for refurbishment

W: 1200 mm · H: 600 mm · D: 300 mm
 up to 42 l/s · up to 150 m³/h fresh air
 Cooling capacity approx. 280 W when used for 5 hours
 Heating capacity up to 2000 W

Façade ventilation units

Project-specific under sill units

Supply and extract air units (ZAB) and secondary air units (SEK)

Traungasse, Vienna, Austria

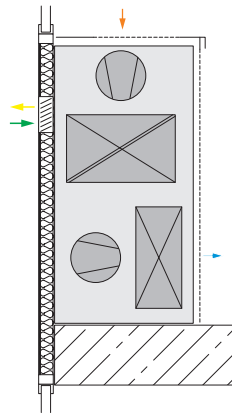

- Mechanical ventilation with heat recovery
- Secondary air unit (SEK) for dealing with thermal loads
- Heat exchanger for heating and cooling
- Under sill installation
- Quasi displacement flow
- Energy efficient radial flow fans
- Controlled/limited fresh air flow rate independent of wind pressure
- Low sound power level

W: 1200 mm · H: 630 mm · D: 320 mm
 28 – 33 l/s · 100 – 120 m³/h fresh air (ZAB)
 Cooling capacity up to 780 W, SEK: 580 W
 Heating capacity to 1780 W, SEK: 790 W

Supply air units with secondary air function (ZUS)

Feldbergstraße, Frankfurt/Main (D)

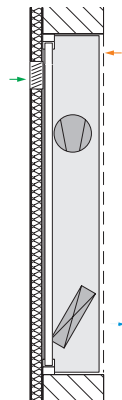

- Mechanical ventilation
- Installation on the sill beside the window
- Quasi displacement flow with 2-way air discharge
- Heat exchanger for heating and cooling
- Energy efficient radial flow fan
- Fan speed control in 3 steps
- Controlled/limited fresh air flow rate independent of wind pressure
- Low sound power level

W: 352 mm · H: 1880 mm · D: 301 mm
 21 l/s · 75 m³/h fresh air
 21 – 58 l/s · 75 – 210 m³/h supply air
 Cooling capacity up to 835 W
 Heating capacity up to 2150 W

Supply and exhaust air units with secondary air function (ZAS)

CAPRICORN Haus, Düsseldorf, Germany

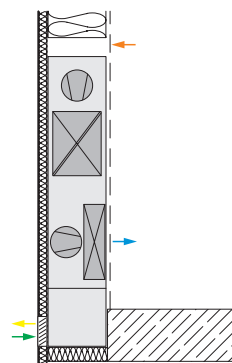

- Mechanical ventilation with heat recovery
- Façade integrated modular design:
Base casing for installation during construction phase
Modular inserts for subsequent fitting
- Quasi displacement flow
- Heat exchanger for heating and cooling
- Supply and extract air mode, mixing with secondary (induced) air, and full secondary (recirculated) air modes are possible
- Energy efficient radial flow fans
- Fan speed controlled in 3 steps
- Controlled/limited fresh air flow rate independent of wind pressure

W: 1065 mm · H: 1065 mm · D: 195 mm
 16 – 33 l/s · 60 – 120 m³/h fresh air
 Cooling capacity up to 460 W
 Heating capacity up to 800 W

Supply and extract air units

Type FSL-U-ZAB

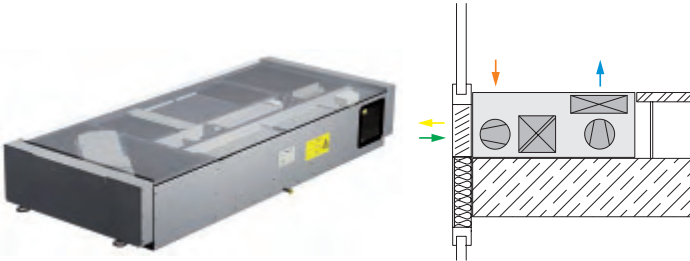

- Mechanical ventilation with heat recovery
- Heat exchanger for heating and cooling
- Static heating possible
- Quasi displacement flow
- Controlled/limited fresh air flow rate independent of wind pressure

W: 1200 mm · H: 200 mm · D: 500 mm

16 – 33 l/s · 60 – 120 m³/h fresh air

Cooling capacity up to 560 W

Heating capacity up to 800 W

Supply air units with secondary air function

Type FSL-U-ZUS

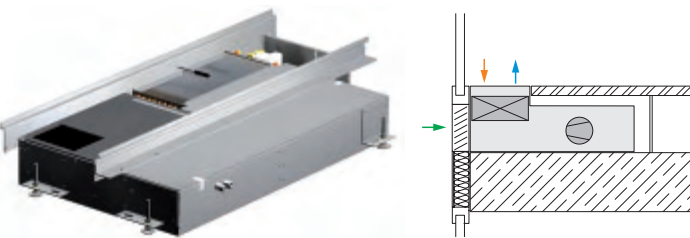

- Mechanical ventilation
- Heat exchanger for heating and cooling
- Quasi displacement flow
- Energy efficient radial flow fan
- Fan speed controlled in 3 steps
- Controlled/limited fresh air flow rate independent of wind pressure

W: from 1100 mm · H: 180 – 230 mm · D: 550 – 640 mm

22 – 33 l/s · 80 – 120 m³/h fresh air

22 – 56 l/s · 80 – 200 m³/h supply air

Cooling capacity up to 930 W

Heating capacity up to 1330 W

Secondary air units

Type FSL-U-SEK

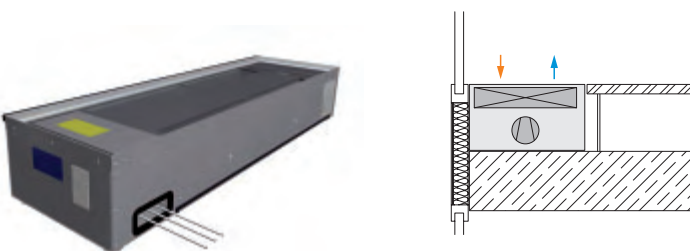

- For dealing with thermal loads
- Heat exchanger for heating and cooling
- Quasi displacement flow
- Energy efficient radial flow fan
- Low sound power level

W: from 1200 mm · H: 212 mm · D: 340 mm

22 – 83 l/s · 80 – 300 m³/h supply air

Cooling capacity up to 792 W

Heating capacity up to 1613 W

Standard/ Guideline	Title	Relevant/important content
EN 13779 2007	Ventilation for non-residential buildings Performance requirements for ventilation and room-conditioning systems	<ul style="list-style-type: none"> • Definition of types of air • Classification of extract air, exhaust air, outdoor air, and indoor air quality • Classification of the specific fan powers (SFP) • Definition of the occupied zone • Recommended minimum filter grades (in the informative appendix)
EN 15251 2007	Indoor environmental input parameters for design and assessment of energy performance of buildings addressing indoor air quality, thermal environment, lighting and acoustics	<ul style="list-style-type: none"> • Recommended air change rates for non-residential buildings with standard occupation • Recommended selection criteria for the humidity in occupied spaces • A-weighted selected sound pressure level
EN ISO 7730 2007	Ergonomics of the thermal environment – Analytical determination and interpretation of thermal comfort using calculation of the PMV and PPD indices and local thermal comfort criteria	<ul style="list-style-type: none"> • Maximum possible average air velocity as a function of the air temperature and the intensity of turbulence • Vertical air temperature difference between head and ankles • Energy exchange
VDI 3804 2009	Ventilation systems for office buildings	<ul style="list-style-type: none"> • Horizontal air discharge systems differ according to the location of the air supply • Typical room temperature curve of various ventilation systems • Permissible range of room air velocities • Humidification of offices by people • Comparison of ventilation systems with heating and cooling functions
VDI 6022 Sheet 1 2006	Hygiene requirements for air conditioning plants and units	<ul style="list-style-type: none"> • Hygiene requirements on design, production, implementation, operation and maintenance • Qualification and training of the personnel • Check lists
VDI 6035 2008	Ventilation and air conditioning technology – Decentralized ventilation systems – Wall-mounted air conditioners (VDI ventilation code of practice)	<ul style="list-style-type: none"> • Division of the units into various types • Requirements, possible applications, application limits • Planning fundamentals: façade, room, unit • Commissioning and acceptance inspection, operation, servicing • Effects of wind • Features of decentralised air conditioning
VDMA 24390 2007	Decentralised ventilation units, quality, and testing guideline	<ul style="list-style-type: none"> • Quality requirements • Testing devices and methods • Definition of the manufacturer's data (comparability)
EN 14240 2004	Ventilation for buildings – Chilled ceilings – Testing and rating.	<ul style="list-style-type: none"> • Definition of testing conditions and methods for determining the cooling capacity • Provision of comparable and reproducible product characteristic values
EN 14518 2005	Ventilation for buildings – Chilled beams – Testing and rating of passive chilled beams.	<ul style="list-style-type: none"> • Definition of testing conditions and methods for determining the cooling capacity • Definition of the method for determining the local air velocity and air temperature underneath the passive chilled beam • Provision of comparable and reproducible product characteristic values
EN 15116 2008	Ventilation for buildings – Chilled beams – Testing and rating of active chilled beams.	<ul style="list-style-type: none"> • Definition of methods for determining the cooling capacity • Provision of comparable and reproducible product characteristic values



Technical leaflets



Project information documents

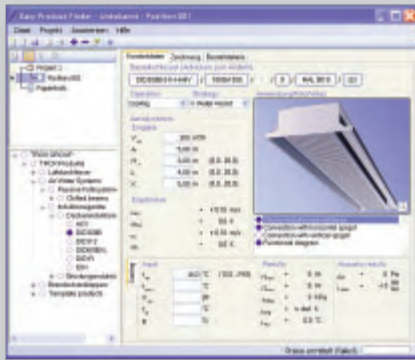

Design programme



Internet

Technical leaflets

Product leaflets

Product description, materials, aerodynamic and acoustic data, and dimensions are contained in the technical leaflets.

All important properties of the units and materials used are described in the specification text. These texts guarantee that only high-quality units are selected for a particular contract.

Project information documents

Many project-specific façade ventilation units are documented in project information documents.

The functional description, design variants, and technical data offer a good conceptual basis for new projects.

Selection of the units using the design programme

The new generation of the **Easy Product Finder** design programme will in future comprise all products in one software programme, as well as providing all important information to enable product selection.

- Technical data
- Product photo, functional diagram, flow visualisation
- CAD drawing (3D model according to VDI 3805, DXF and other formats)
- Specification text that deals with the product and its variants
- Product installation in building

TROX on the Internet

www.trox.de

The entire documentation has been published on the Internet.

In addition, you will find a wide range of installation examples and reference projects for our products and systems.

Integrated design and cooperative development process

Air-water systems are usually project-specific solutions involving many functions. For this reason, joint design process is absolutely fundamental in terms of capacities, units required and interfaces, from conception, construct and on to commissioning. The cooperative development process is essential to ensure that a project is completed on time and the required performance achieved.



Capricorn House, Düsseldorf, Germany

Building concept



- **Tasks**
Definition of use and building layout, dimensions, shape and size of the building, concepts for the building services equipment, façade system and design
- **Participants**
Owner, architect, and project developer
- **TROX CUSTOMER SUPPORT**
Support during system analysis and selection
Feasibility study

Room and story planning



- **Tasks**
Definition of the room types and standard floors, determination of the ceiling, floor, and façade construction, derivation of the unit functions, calculation of the required cooling and heating capacities, definition of possible installation locations and possible dimensions, definition of interfaces to other units
- **Participants**
Architect and Specialist consultant
- **TROX CUSTOMER SUPPORT**
Creation of a unit concept based on the project-specific requirements

Unit design



- **Tasks**
Unit construction and determination of the unit capacity
Installation and connection design (air, water, electrical)
Control engineering and centralised building management system design
- **Participants**
Specialist consultant for all units included in the project and Main contractor, Services installation company and Control engineering company
- **TROX CUSTOMER SUPPORT**
Detailed unit development and sizing, building of prototypes and performance measurement, tender documents with unit description, technical data and drawings

Project completion



- **Tasks**
Unit production, installation and connection of all units, commissioning and acceptance
- **Participants**
Specialist consultant and Services installation company for all units included in the project
- **TROX CUSTOMER SUPPORT**
Manufacturing and delivery, assembly and operating manuals, Commissioning



IBC, Frankfurt, Germany

Post Tower, Bonn, Germany



Constitution Center, Washington, DC, USA



City of Justice, Barcelona, Spain

Alu

Brixen, Italy

Antwerp Tower

Antwerp, Belgium

Busbahnhof

Unna, Germany

Capricorn House

Düsseldorf, Germany

Chambre de Commerce

Luxembourg, Luxembourg

City of Justice

Barcelona, Spain

Constitution Center

Washington, USA

Daimler Chrysler

Sindelfingen, Germany

DEG Zentrale

Köln, Germany

Dexia BIL

Luxembourg, Luxembourg

EBH Bank

Denmark

European Investment Bank

Luxembourg, Luxembourg

Feldbergstraße

Frankfurt am Main, Germany

Greater London Authority

London, Great Britain

Helvea

Zürich, Switzerland

Investment Banking Centre

Frankfurt am Main, Germany

Imtech Haus

Hamburg, Germany

European Investment Bank,
Luxembourg



KIA

Frankfurt am Main, Germany

Laimer Würfel

München, Germany

Mannheimer Insurance

Mannheim, Germany

Messehalle 3

Frankfurt am Main, Germany

Messehalle 11

Frankfurt am Main, Germany

Messezentrum

Salzburg, Austria

Migros

Genf, Switzerland

Mondrian EU-Administration

Brüssel, Belgium

Neumühlequai

Zürich, Switzerland

Nestlé

Vevey, Switzerland

Post Tower

Bonn, Germany

Office am See

Bregenz, Austria

Paul Scherrer Institut

Villingen, Switzerland

RAMADA Hotel

Solothurn, Switzerland

Swiss Post Office

Chur, Switzerland

Norwich Union HQ

Norwich, Great Britain

SKYLINK Flughafen

Wien, Austria

Sky Office

Düsseldorf, Germany

St. Phillips Academy

New Jersey, USA

Swarovski

Wattens, Austria

Telefónica

Madrid, Spain

Thuringia Insurance

München, Germany

Traungasse

Wien, Austria

University

Amsterdam, Netherlands

University

Fribourg, Switzerland

University Hospital

Zürich, Switzerland

WHG-Bürgleinstraße

München, Germany

Headquarters Germany

TROX GmbH

Heinrich-Trox-Platz

D-47504 Neukirchen-Vluyn

Phone +49(0)28 45 / 2 02-0

Fax +49(0)28 45 / 2 02-2 65

E-Mail trox@trox.de

www.troxtechnik.com

Subsidiaries and Sales Offices

Argentina

TROX Argentina S.A.

Australia

TROX Australia Pty Ltd

Austria

TROX Austria GmbH

Belgium

S.A. TROX Belgium N.V.

Brazil

TROX do Brasil Ltda.

Bulgaria

TROX Austria GmbH

China

TROX Air Conditioning Components
(Suzhou) Co., Ltd.

Croatia

TROX Austria GmbH

Czech Republic

TROX Austria GmbH

Denmark

TROX Danmark A/S

France

TROX France Sarl

Germany

FSL GmbH & Co. KG
TROX Deutschland GmbH
TROX Filter GmbH

Great Britain

TROX UK Ltd.
TROX AITCS Ltd.

Hong Kong

TROX Hong Kong Ltd.
TROX AITCS Ltd.

Hungary

TROX Austria GmbH

India

TROX INDIA PRIVATE LIMITED

Italy

TROX Italia S.p.A.

Malaysia

TROX Malaysia Sdn. Bhd.

Norway

TROX Auranor Norge AS

Poland

TROX Austria GmbH

Romania

TROX Austria GmbH

Russia

000 TROX RUS

Serbia

TROX Austria GmbH

South Africa

TROX South Africa (Pty) Ltd

Spain

TROX España, S.A.

Sweden

TROX Sverige AB

Switzerland

TROX HESCO Switzerland AG

United Arab Emirates

TROX Middle East (LLC)

USA

TROX USA, Inc.
TROX AITCS Ltd.

International Representatives

Abu Dhabi

Bosnia-Herzegovina

Chile

Cyprus

Egypt

Finland

Greece

Iceland

Indonesia

Iran

Ireland

Israel

Jordan

Korea

Latvia

Lebanon

Lithuania

Mexico

Morocco

Netherlands

New Zealand

Oman

Pakistan

Philippines

Portugal

Saudi Arabia

Slovak Republic

Slovenia

Sweden

Taiwan

Thailand

Turkey

Ukraine

Uruguay

Venezuela

Vietnam

Zimbabwe